

Kenworth

LH-D 230/270 SERIES



© 1987 KENWORTH TRUCK COMPANY, INC.

5CR

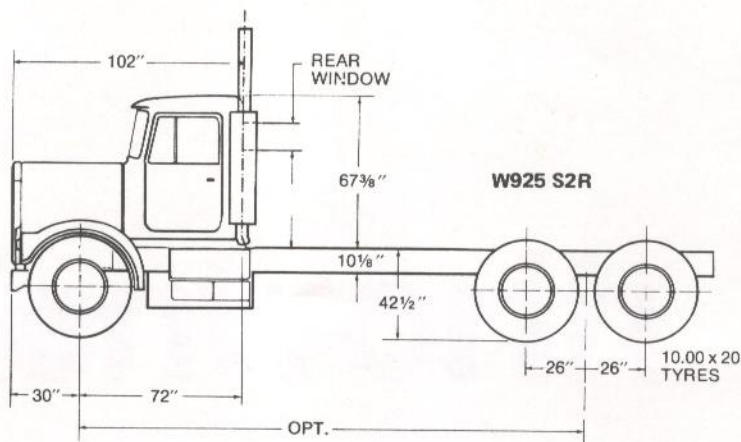
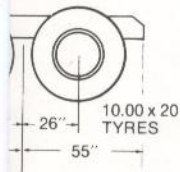

LH-D 270

K125 CR — 270
W925 S2R — 270

STANDARD SPECIFICATIONS

Three axle truck (6 x 4) single reduction rear axle.
160" wheelbase. Bumper setting 28".
50,000 lb. G.V.M. 100,000 lb. G.C.M.

SPECIFICATIONS INCLUDE

ENGINE: Detroit Diesel 6V92TT, 552 cu.in., 270 hp
1950 rpm. By-pass oil filter, water filter and fuel filter,
14" dual dry type air cleaner, 22" diameter fan, fuel
filter, single exhaust.

RADIATOR: 1200H4 core, cadmium plated grille and
full radiator shroud.

ELECTRICAL EQUIPMENT: Leece-Neville 75-amp
generator, 12-volt lighting, 24-volt starting. Four 6-volt
15-plate batteries.

TRANSMISSION: Fuller Roadranger RT915, 15 speed
with 14" two-plate clutch. SAE # 1 bellhousing, cast
iron case.

PROPELLER SHAFTS: Spicer 1710 Series needle
bearing, balanced tubing.

FRONT AXLE: Rockwell FF-931-TW, 12,000 lb.
capacity. Front axle shock absorbers.

REAR AXLE: Eaton DS 380 (3.90:1) on Kenworth
"Spherical" torsion bar suspension with 38,000 lb.
capacity.

SERVICE BRAKES: Rockwell "S" cam air brakes.
12 CFM B/W compressor, quick release valve and
front wheel limiting valve. Flexible air piping.
Brake size front: 15" x 4" — area 246 sq. ins. Brake
size rear: 16 1/2" x 7" — area 868 sq. ins. Air operated
emergency release system on parking brakes.

TYRES: 10.00 x 20, 12-ply, highway tread (ten furn-
ished).

WHEELS: Spoke type 7.5" x 20" rims (eleven furn-
ished).

FRAME: Heat treated alloy steel channel. Dimensions:
10 1/8" depth, 3/4" flanges, 5/16" thickness, free fit all
bolted construction.

CAB: Kenworth cab. Steel frame, aluminium bulkhead
doors with continuous weather seals and piano type
hinges. Windscreen laminated safety glass throughout.
Air ride driver's seat, toolbox rider's seat, dome light,
dual motor air windscreen wipers, windscreen washers,
sunvisors, cigar lighter, ashtrays, Grover air horn, electric
horn, dual exterior mirrors. Console tilt out dash.
Instruments: Speedometer, tachometer, fuel gauge,
ammeter, oil pressure, water temperature and air reservoir
pressure gauges, low pressure wig-wag, low oil temperature
and high water temperature warning lights. Lights: Dual
headlights, park lights, amber turn signals, stop, turn, and
tail lamps.

SPECIAL EQUIPMENT: Heater/demister-cab fan, lap/
sash belts on both seats deluxe cab and door trim.

FUEL TANK: 380 litre aluminium.

STEERING GEAR: Sheppard model 492 Integral power
steering and 22" diameter adjustable steering wheel.

STANDARD EQUIPMENT: Aluminium bumper with
integral tow hook. Spare rim, wheel wrenches and 12
ton hydraulic jack. Steel battery box.

PAINT: Low bake enamel in any one colour.

Specifications subject to change without notice.

