

DEFINING TOMORROW

T909



● T909

Kenworth's tradition of classic styling continues with the T909, but it offers much more than rugged long-bonneted good looks. With the capacity to handle 615 peak horsepower engines, the T909 is versatile enough to operate in almost any application from logging to livestock, pulling a single trailer or a triple road train, where the front axle weight is critical.



● ADR 80/03 - THE NEW AUSTRALIAN EMISSIONS STANDARD

For the T909 the emission solution employed to meet ADR 80/03 in the 2011 model range powered by Cummins ISX and Signature engines is cooled Exhaust Gas recirculation (EGR).

Kenworth is introducing a Cummins Particulate Filter as part of the engine package. The Cummins Particulate Filter, which replaces the existing vehicle muffler, reduces particulate emissions by 90% from ADR80/02 levels and is designed to last the life of the engine.

Kenworth's application engineering process has delivered an optimised solution and integrates EGR seamlessly across the high horsepower engine options. So as well as being highly efficient and low maintenance the EGR emission solution has little or no impact on payload and efficiency. Kenworth customers get the emission compliance they need with the proven performance and reliability of engines they know and trust – all with the back up of our renowned local design and manufacturing capability and Australia wide support network.

● EBSS - ELECTRONIC BRAKE SAFETY SYSTEM

At Kenworth, safety has always been a paramount consideration, and we continue to invest heavily in developing a safer working environment for road transport operators and other road users. All 2011 new model Kenworth's are available with the latest Kenworth EBSS Safety Package. EBSS incorporates a variety of safety features including ABS, Drag Torque Control, Traction Control and ESP.

Kenworth EBSS has been designed to provide a class leading and reliable system for Australasia's unique road conditions and applications, and deliver better peace of mind for all road users. To learn more about these safety systems see www.kenworth.com.au

T909 36" FLAT BACK SLEEPER

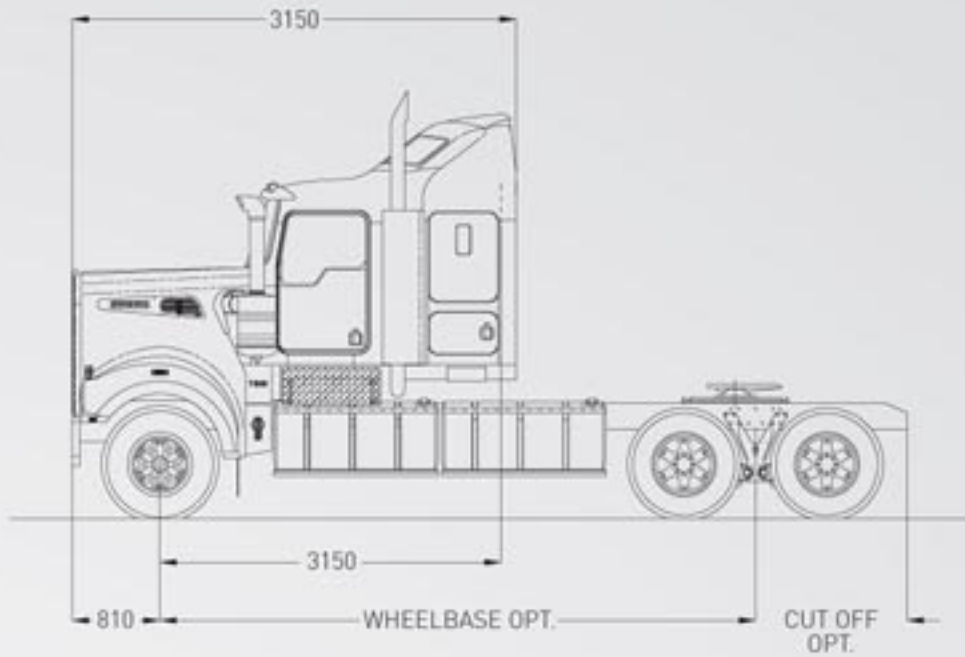

T909 915MM MODULAR SLEEPER AERO 11 ROOF

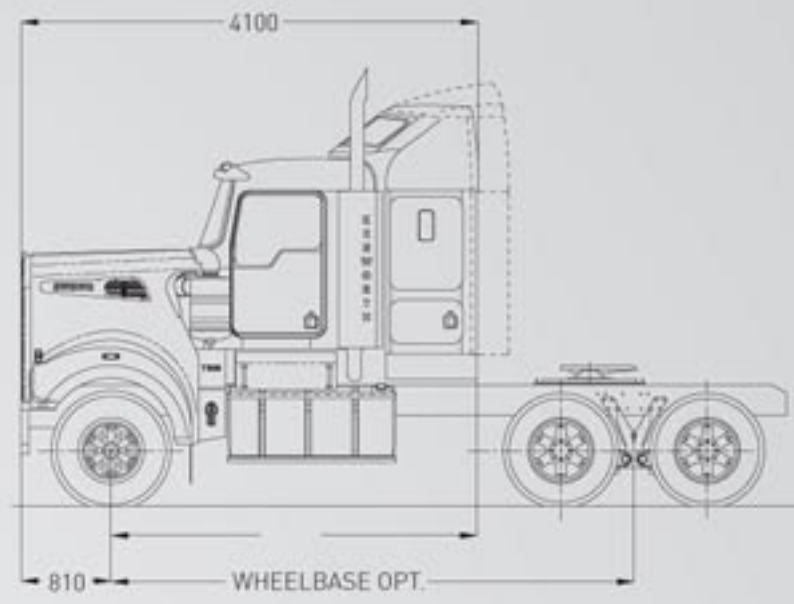

T909 28" IT SLEEPER

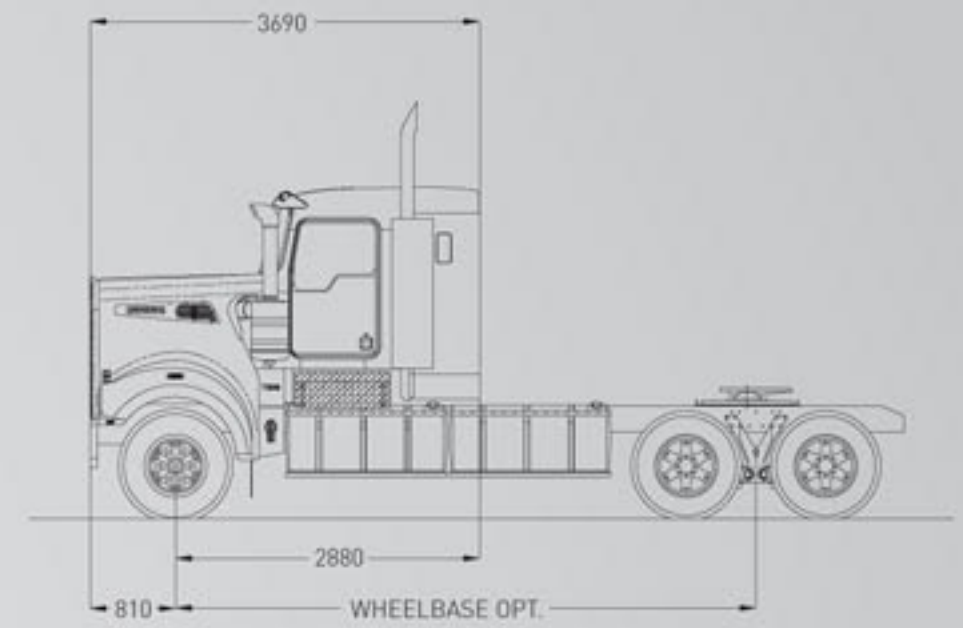

T909 1270MM MODULAR SLEEPER

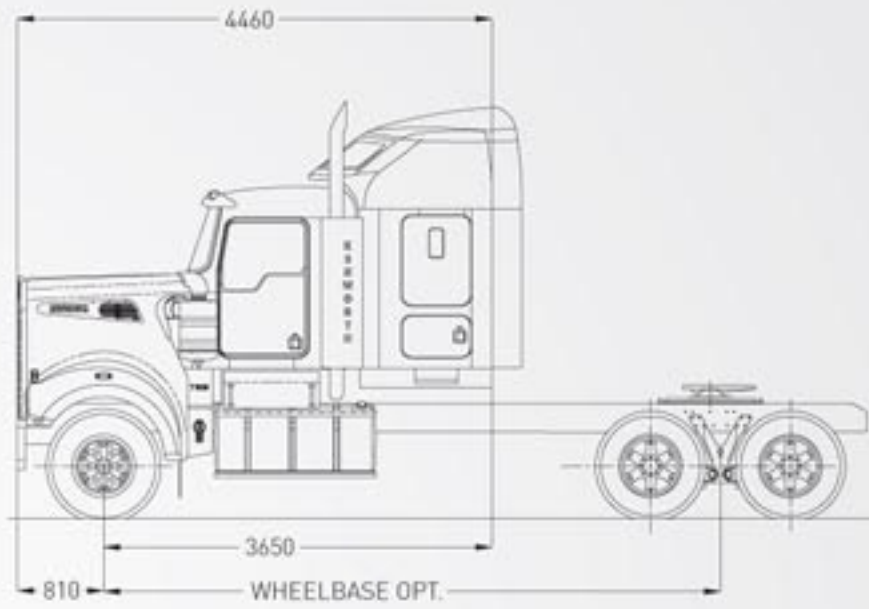

T909 AERO 50" INTEGRATED SLEEPER

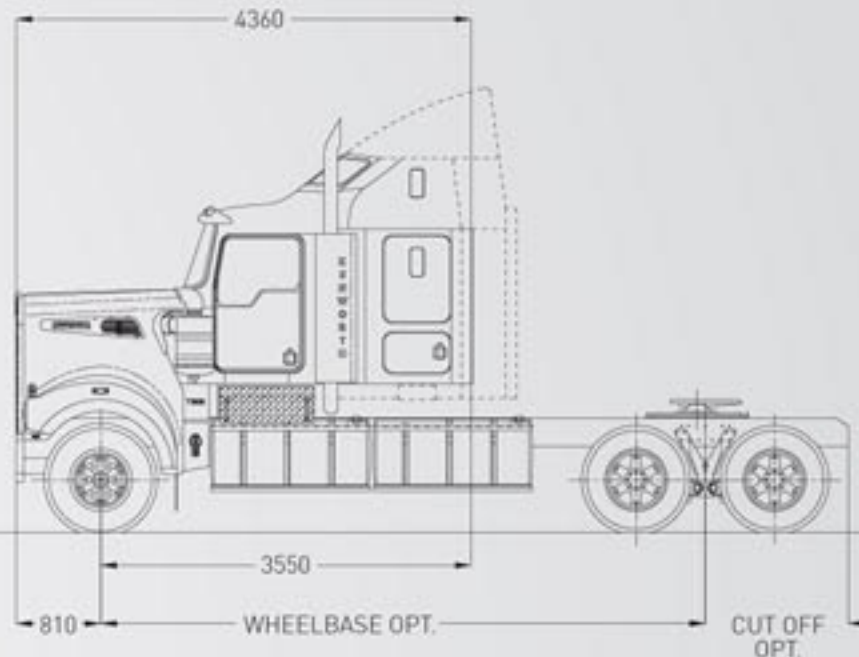

T909 36" RECESSED BACK SLEEPER

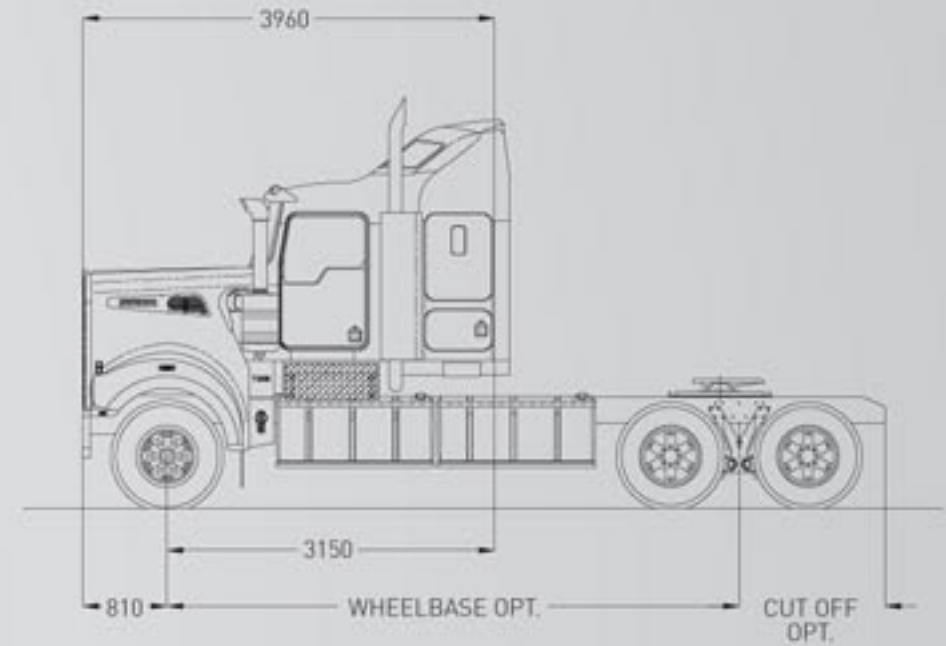

T909 DAY CAB

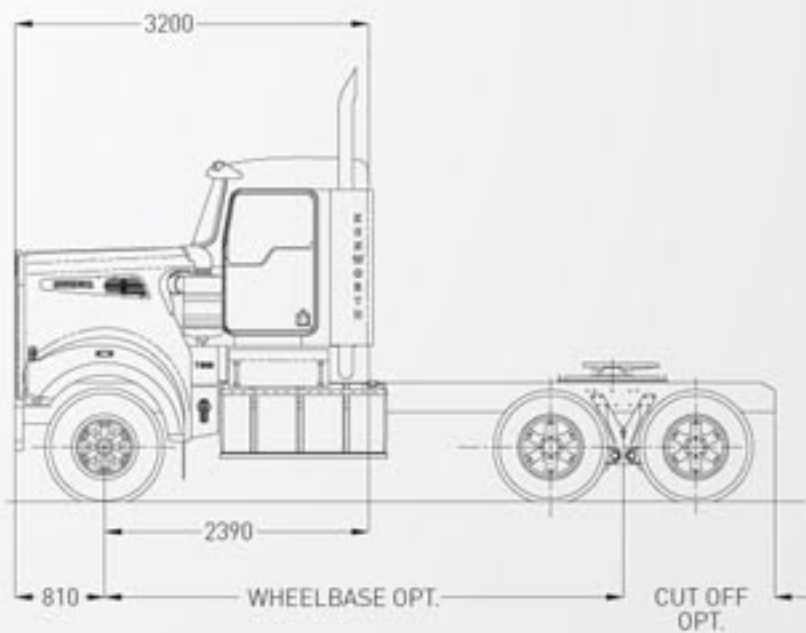

T909 915MM MODULAR SLEEPER

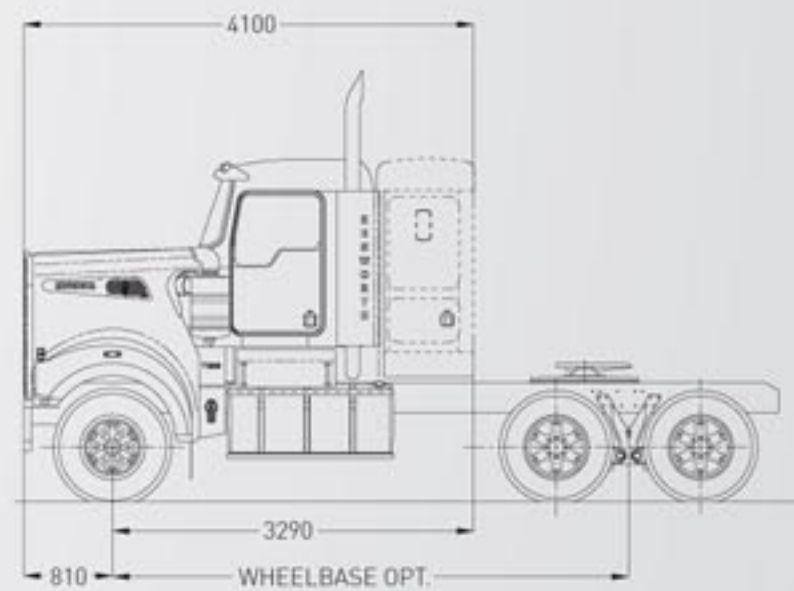

T909 1270MM MODULAR SLEEPER

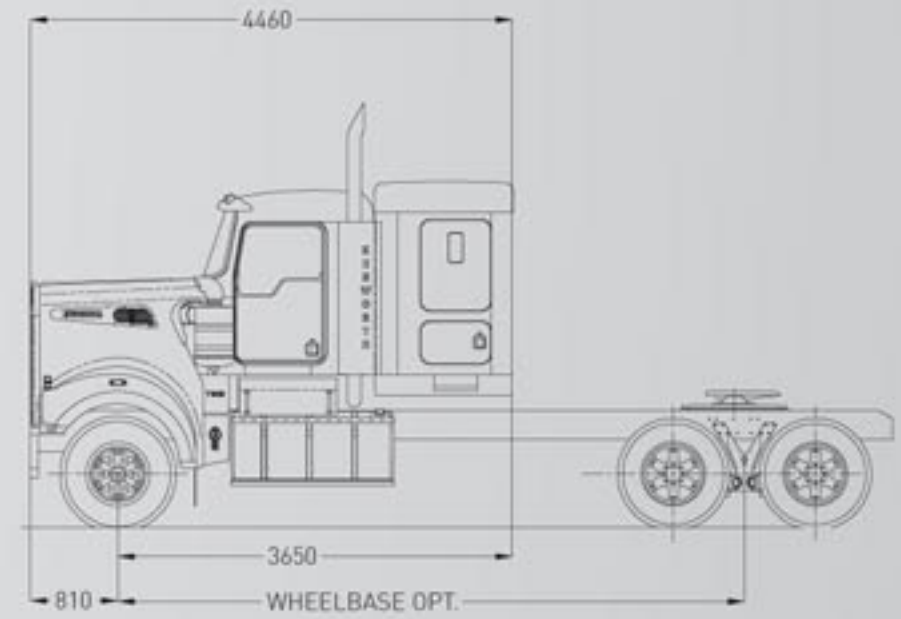

MAIN SPECIFICATIONS AND OPTIONS

CONFIGURATION

- 6X4 **standard**
- 8X4 **optional**

KITS

- FUEL HAUL & GAS HAUL **optional**

ENGINE

- ISX EGR 485HP @ 1650LBFT TORQUE **standard**
- ISX EGR 485HP @ 1850LBFT TORQUE **optional**
- ISX EGR 500HP @ 1850LBFT TORQUE **optional**
- ISX EGR 525HP @ 1850LBFT TORQUE **optional**
- ISX EGR 550HP @ 1850LBFT TORQUE **optional**
- ISX EGR 600HP @ 1850LBFT TORQUE **optional**
- SIGNATURE 600HP @ 2050LBFT TORQUE **optional**

EXHAUST

- DPF MOUNTED RIGHT HAND FORWARD **standard**
- DPF MOUNTED UNDER CHASSIS **optional**
- POST MOUNTED DPF (DAY CAB ONLY) **optional**

AIR CLEANER

- DUAL 356MM CYCLOPACS COWL MOUNTED **standard**
- DUAL 406MM CYCLOPACS COWL MOUNTED **optional**

TRANSMISSION

- EATON RTLO16918B **standard**
- Up to EATON RTLO22918B **optional**
- Up to EATON RTLO18913A **optional**

- Up to EATON RTLO22918A-AS3 **optional**

- ULTRASHIFT PLUS
 - FO-16E318B-MXP
 - FO-18E318B-MXP
 - FO-20E318B-MXP
 - FO-22E318B-MXP

FRONT AXLE

- DANA E-1462I **standard**
- MERITOR FG941 **optional**
- MFS73 **optional**

REAR AXLE

- DANA DSH40P **standard**
- DANA D46-170 **optional**
- DANA D50 - 170 **optional**
- DANA D52-190 **optional**
- DANA D52 - 190 WITH LAZY AXLE **optional**
- MERITOR RT40-145 **optional**
- MERITOR RT46-160 **optional**
- MERITOR RT50-160 **optional**
- MERITOR RT52-185 **optional**
- MERITOR RT52-185 WITH LAZY AXLE **optional**
- MERITOR RZ78-188G TRI-DRIVE **optional**

REAR SUSPENSION

- KENWORTH AIRGLIDE 400 **standard**
- KENWORTH AIRGLIDE 460 **optional**
- KENWORTH KW6-60A **optional**
- NEWAY AD246/10 **optional**
- NEWAY AD369/10 (8X4 OR 8X6 ONLY) **optional**

BRAKES

- DRUM **standard**
- DISC **optional**

WHEELS

- 6 SPOKE **standard**
- ALCOA 10 STUD **optional**

SLEEPER

- 28" IT **optional**
- 36" AERO RECESSED BACK **optional**
- 36" AERO FLAT BACK **optional**
- 36" MID ROOF SLEEPER **optional**
- 50" AERO FLAT BACK **optional**
- 915MM FLAT ROOF **optional**
- 915MM AERO II **optional**
- 1270MM AERO II **optional**

FUEL TANKS

- 450L 625MM DIA FUEL TANK LEFT HAND FORWARD **standard**
- RANGE OF PACKAGES AVAILABLE **optional**

PAINT

- SINGLE COLOUR TO CAB **standard**
- UP TO 3 COLOURS 6 BREAKS **optional**

GCM

- 90 TONNE LIMIT*



* higher rating subject to application approval

THE BEST DEALER NETWORK

Kenworth has built an extensive truck dealer network across Australia that is renowned for its professionalism and excellence in the heavy duty truck industry. The Kenworth dealer network also includes highly qualified dealers in New Zealand and Papua New Guinea.



For more information contact your local Kenworth Dealer or go to www.kenworth.com.au

IMPORTANT: The vehicles shown in this brochure are for illustrative purposes only and may include some non-standard optional equipment. All weights and measurements should be regarded as approximate only. For full details contact your Kenworth Dealer. In the interests of product improvement, Kenworth reserves the right to change these specifications without prior notice.

PACCAR Australia Pty Ltd,
64 Canterbury Road, Bayswater, Victoria 3153

Telephone [03] 9721 1500
Facsimile: [03] 9720 4144

PACCAR



PACCAR FINANCIAL