

DEFINING TOMORROW

T659



## ● T659

Rugged, reliable and tough, the Kenworth T659 is designed and built to handle the most brutal jobs this country has to offer, both on and off the highway. Whether you need to haul a triple road train on a back road, or a load of logs out of a forest, you'll do it easily and in more comfort and safety when you're behind the wheel of a T659.



## ● ADR 80/03 - THE NEW AUSTRALIAN EMISSIONS STANDARD

For the T659 the emission solution employed to meet ADR 80/03 in the 2011 model range powered by Cummins ISX and Signature engines is cooled Exhaust Gas Recirculation (EGR).

Kenworth is introducing a Cummins Particulate Filter as part of the engine package. The Cummins Particulate Filter, which replaces the existing vehicle muffler, reduces particulate emissions by 90% from ADR 80/02 levels and is designed to last the life of the engine.

Kenworth's application engineering process has delivered an optimised solution that integrates EGR seamlessly across the high horsepower engine options. So as well as being highly efficient and low maintenance the EGR emission solution has little or no impact on payload and efficiency. Kenworth customers get the emission compliance they need with the proven performance and reliability of engines they know and trust – all with the back up of our renowned local design and manufacturing capability and Australia wide support network.

## ● EBSS - ELECTRONIC BRAKE SAFETY SYSTEM

At Kenworth, safety has always been a paramount consideration, and we continue to invest heavily in developing a safer working environment for road transport operators and other road users. All 2011 new model Kenworth's will be available with the latest Kenworth EBSS Safety Package. EBSS incorporates a variety of safety features including ABS, Drag Torque Control, Traction Control and ESP.

Kenworth EBSS has been designed to provide a class leading and reliable system for Australasia's unique road conditions and applications, and deliver better peace of mind for all road users. To learn more about these safety systems visit [www.kenworth.com.au](http://www.kenworth.com.au)

## NEW FEATURES

The new Kenworth T659 features a wide range of important enhancements- from significant driver environment improvements to the new trim colours and additional safety features. New doors have been introduced with electric windows as standard, new heavy duty steel key, wider more comfortable arm rests and improved Heater, Ventilation and Air Conditioner Units to keep you warmer in winter and cooler in summer.

The 2011 range also sees the introduction of the new Eaton "Ultrashift plus" automated transmissions. This two-pedal transmission delivers significant improvements in performance, superior acceleration and low speed manoeuvrability with its revolutionary Electronic Clutch Actuation (ECA).

## NEW DOORS



T659 DAY CAB

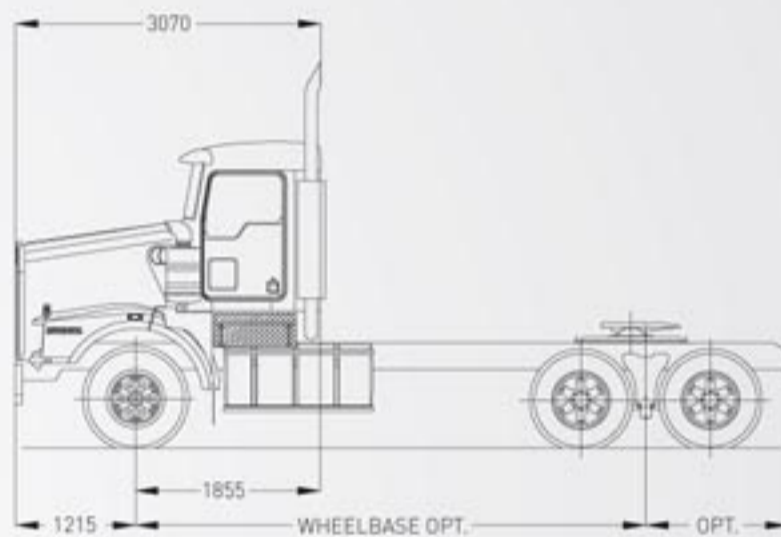

T659 915MM SLEEPER BOX  
FLAT ROOF

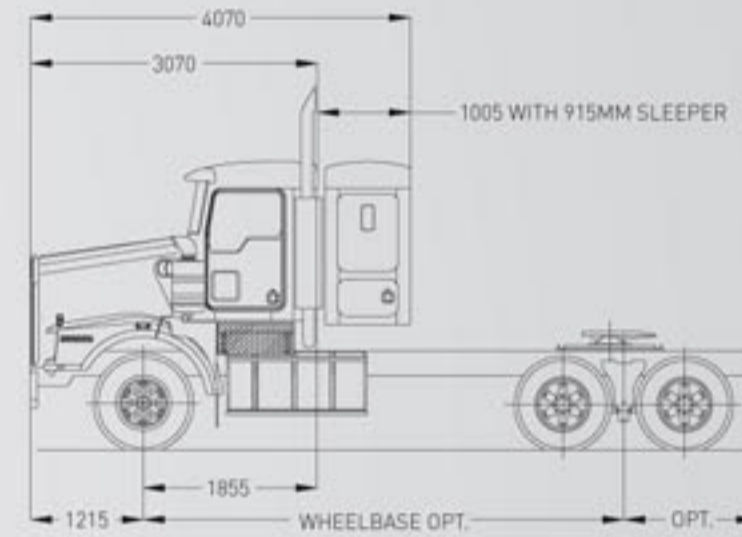

T659 915MM SLEEPER BOX  
AERO II ROOF

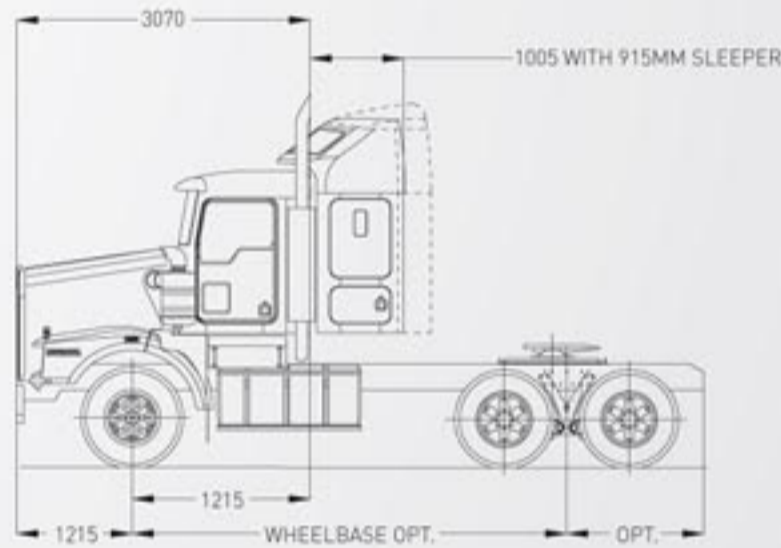

T659 1270MM SLEEPER BOX  
AERO II ROOF

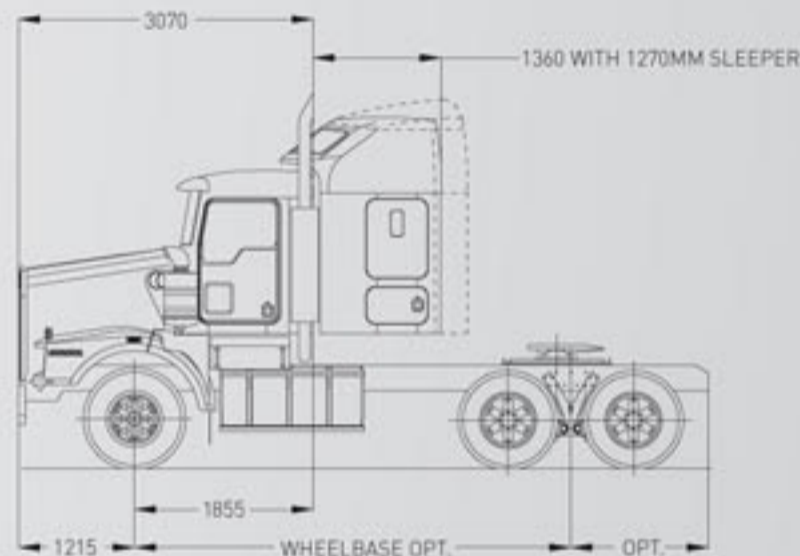

## MAIN SPECIFICATIONS AND OPTIONS

### CONFIGURATION

- 6X4 **standard**
- 8X4 **optional**
- 8X6 **optional**

### KITS

- FUEL HAUL & GAS HAUL **optional**

### ENGINE

- ISX EGR 485HP @ 1650LBFT TORQUE **standard**
- ISX EGR 485HP @ 1850LBFT TORQUE **optional**
- ISX EGR 500HP @ 1850LBFT TORQUE **optional**
- ISX EGR 525HP @ 1850LBFT TORQUE **optional**
- ISX EGR 550HP @ 1850LBFT TORQUE **optional**
- ISX EGR 600HP @ 1850LBFT TORQUE **optional**
- SIGNATURE 600HP @ 2050LBFT TORQUE **optional**

### EXHAUST

- DPF MOUNTED UNDER CAB RIGHT HAND FORWARD **standard**
- DPF MOUNTED UNDER CHASSIS **optional**
- DPF POST MOUNTED (DAY CAB ONLY) **optional**

### AIR CLEANER

- DUAL 356MM CYCLOPAC COWL MOUNTED **standard**
- DUAL 406MM CYCLOPAC COWL MOUNTED **optional**

### TRANSMISSION

- EATON RTLO16918B **standard**
- Up to EATON RTLO22918B **optional**
- Up to EATON RTLO18913A **optional**
- Up to EATON RTLO22918A-AS3 **optional**
- ULTRASHIFT PLUS
  - FO - 16E318B - MXP **optional**
  - FO - 18E318B - MXP **optional**
  - FO - 20E318B - MXP **optional**
  - FO - 22E318B - MXP **optional**

### FRONT AXLE

- DANA E-1462I **standard**
- MERITOR FG941 **optional**
- MERITOR MFS73 **optional**
- MERITOR FL941 **optional**

### REAR AXLE

- DANA DSH40P **standard**
- DANA D46-170 **optional**
- DANA D50 -170 **optional**
- DANA D52-190 **optional**
- DANA D52-190 WITH LAZY AXLE **optional**
- MERITOR RT40-145 **optional**
- MERITOR RT46-160 **optional**
- MERITOR RT50-160 **optional**
- MERITOR RT52-185 **optional**
- MERITOR RT52-185 WITH LAZY AXLE
- MERITOR RZ78-188G TRI-DRIVE **optional**

### REAR SUSPENSION

- KENWORTH AIRGLIDE 400 **standard**
- KENWORTH AIRGLIDE 460 **optional**
- KENWORTH KW6-60A **optional**
- NEWAY AD246/10 **optional**
- NEWAY AD369/10 **optional**

### BRAKES

- DRUM **standard**
- DISC **optional**

### WHEELS

- 6 SPOKE **standard**
- ALCOA 10 STUD **optional**

### SLEEPER BOXES

- 915MM FLAT ROOF **optional**
- 915MM AERO II **optional**
- 1270MM AERO II **optional**

### FUEL TANKS

- 450L 625MM DIA FUEL TANK LEFT HAND FORWARD **standard**
- RANGE OF PACKAGES AVAILABLE **optional**

### PAINT

- SINGLE COLOUR TO CAB **standard**
- UP TO 3 COLOURS 6 BREAKS **optional**

### GCM

- 90 TONNE LIMIT\*



\* higher rating subject to application approval

# THE BEST DEALER NETWORK

Kenworth has built an extensive truck dealer network across Australia that is renowned for its professionalism and excellence in the heavy duty truck industry. The Kenworth dealer network also includes highly qualified dealers in New Zealand and Papua New Guinea.



For more information contact your local Kenworth Dealer or go to [www.kenworth.com.au](http://www.kenworth.com.au)

**IMPORTANT:** The vehicles shown in this brochure are for illustrative purposes only and may include some non-standard optional equipment. All weights and measurements should be regarded as approximate only. For full details contact your Kenworth Dealer. In the interests of product improvement, Kenworth reserves the right to change these specifications without prior notice.

PACCAR Australia Pty Ltd,  
64 Canterbury Road, Bayswater, Victoria 3153

Telephone (03) 9721 1500  
Facsimile: (03) 9720 4144

## PACCAR



## PACCAR FINANCIAL