

T401



AUSTRALIAN MADE. WORLD'S BEST.

"In a fiercely competitive environment, where light tare weight and rugged reliability are business essentials, the Kenworth T401's performance characteristics are excellent.

When you add Kenworth's build flexibility and options, you have an exceptional package."

Unconventional Benefits

If you need big horsepower and low tare weight, look at the advantages of the Kenworth T401.

Here's a truck to give you a professional edge, designed and built in Australia to the standards that have made Kenworth the first choice when quality really matters.

From the inside looking out, it is immediately apparent that forward vision is exceptional. The curved one-piece windscreen and aerodynamic sloping bonnet, ensure a wide, unobstructed view forwards. A two-piece windscreen is also available. Glancing sideways, the DAYLITE doors, with their drop-down glass section, ensure that drivers can see clearly, adding to safety and substantially reducing the risk of side impact, particularly in tight manoeuvring situations.



Excellent all round visibility.

Your Choice of Contemporary or Classic Styling

For those who prefer the classic lines of the traditional Kenworth hood, we introduce the T401T, with all the features, benefits and options of the T401.

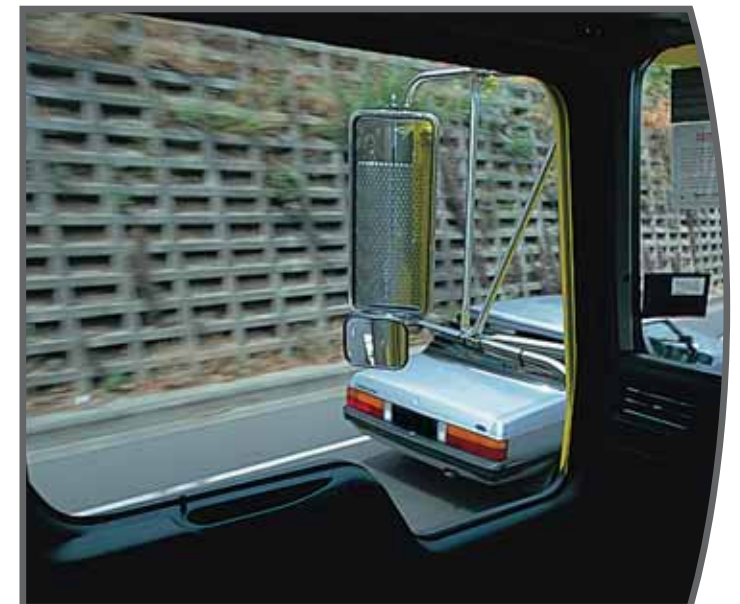

DAYLITE door standard.



The contemporary style of the T401...



... or the classic lines of the T401T.

Driver Satisfaction

The ergonomics of the cab clearly have the professional driver in mind. They're designed so that vital functions fall readily to hand or eye without the need for excessive movement or distraction.

Ergonomically designed with both safety and comfort in mind, the wrap around overhead console and dash set a new standard for cab design in Australia. The dashboard features an area for the mounting of a mobile phone and locations for CB and UHF radios, dual drink holders and a clear line of sight for all gauges – unobscured by the steering wheel. The overhead console houses airconditioner controls, AM/FM radio/CD and electrical switches.



Kenworth control centre.



Mobile office.



Comfort and space.



Wrap around overhead console.

Tare Weight Advantage

Reduced tare weight is the culmination of an improved cab design and the latest engine technology, which offers higher horsepower from smaller engines. Design changes to the suspension system have also helped reduce tare weight. In extreme applications, optional design features like the T401's external air cleaner system and alloy bumper package provide additional protection.

All the Power You Need

Available with a choice of CAT or Cummins engines up to 450hp with 1650lb/ft torque.



*The ideal truck for vocational,
urban and intra-state applications.*

Integrated Cab Options

Kenworth's T401 offers three exciting variants: the T401 IT, the T401 AERO and T401 36" Flat Roof.

With the cab and sleeper now fully integrated, the driver will instantly notice the roominess throughout the cab and sleeper. Movement within the cab and sleeper is easier than ever before. The added benefit of being able to fold both seats back almost horizontally allows each driver to achieve their optimum seating position while driving or relaxing.

This range of options is also available on the traditionally styled T401T.



Tipper and dog application.

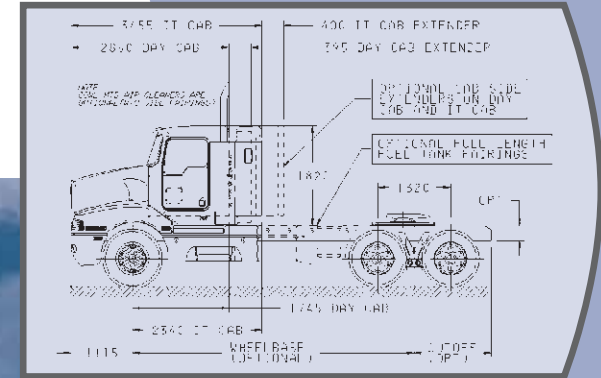

T401 with day cab or IT cab.

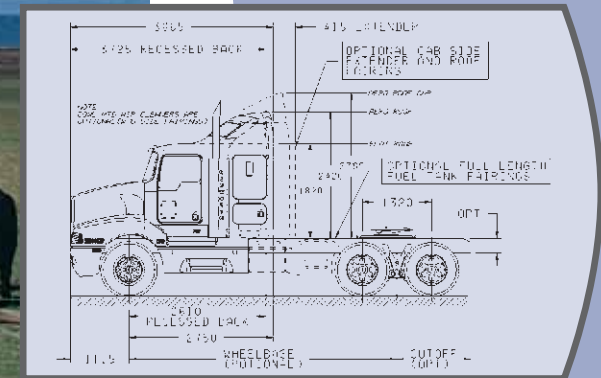

T401 with flat roof recessed back Aero 36\"/>

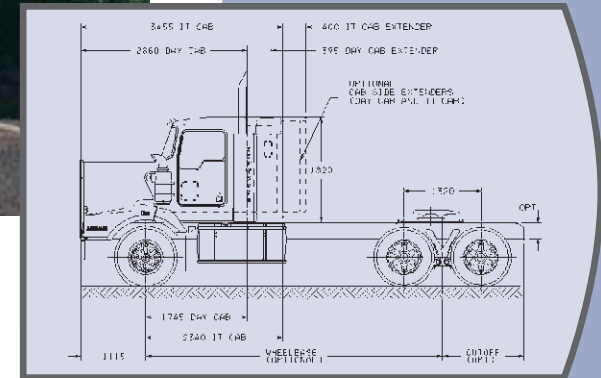

T401T with day cab or IT cab.



Kenworth's T401 has everything going for it – big truck styling in a compact package, the power you need, the economy of exceptionally fuel efficient engines, road and load friendly suspensions, and superior driver comfort too.





The Most Professional National Dealer Network

Every Kenworth truck is supported in the field by a comprehensive network of highly qualified dealers situated throughout Australia, New Zealand and Papua New Guinea. Each has a history of excellence in the heavy duty truck industry. An on-line computerised parts system ensures that Kenworth dealers provide a parts service to owners that is second to none. What's more, each dealership has a complete Bill of Material for every Kenworth truck built. So, when you want a part for your truck, there's no guesswork.

Made in Australia

Kenworth trucks are designed and manufactured in Australia to perform in some of the toughest and most demanding applications anywhere in the world. They are application-engineered to exacting standards, using the best in technology and componentry. On a whole-of-life cost basis, there are few trucks that come anywhere near Kenworth in helping to produce a better bottom line for your business.

www.kenworth.com.au



ABN 43 004 669 667



Quality
Endorsed
Company
ISO9001:2000
Lic-4676
Standards Australia

IMPORTANT

The vehicles shown in this brochure are for illustrative purposes only and may include some non-standard optional equipment. All weights and measurements should be regarded as approximate only. For full details please contact your Kenworth Dealer. In the interests of product improvement, Kenworth reserves the right to change these specifications without prior notice.

07052000

Plant History

- 1969: 28 acres of land purchased at Bayswater.
- 1970: A 56,000 sq/ft factory and office complex completed to produce trucks on a kit assembly basis.
- 1971: The first Australian-made Kenworth – a K100C built and delivered to Comet Overnight Transport.
- 1978: The plant expanded to 100,000 sq/ft to keep up with production demand.
- 1986: PACCAR Parts warehouse and distribution centre built at Bayswater, comprising 51,000 sq/ft.
- 1996: The production plant expanded a further 30,000 sq/ft, after a dynamometer facility ('93), training facilities ('88) and a staff canteen ('88) were added.
- 1998: PACCAR Parts warehouse extended by 52,000 sq/ft to over 100,000 sq/ft.
- 2005: 30,000th Australian made Kenworth delivered.

