

FLEET-LINER SPECIFICATIONS

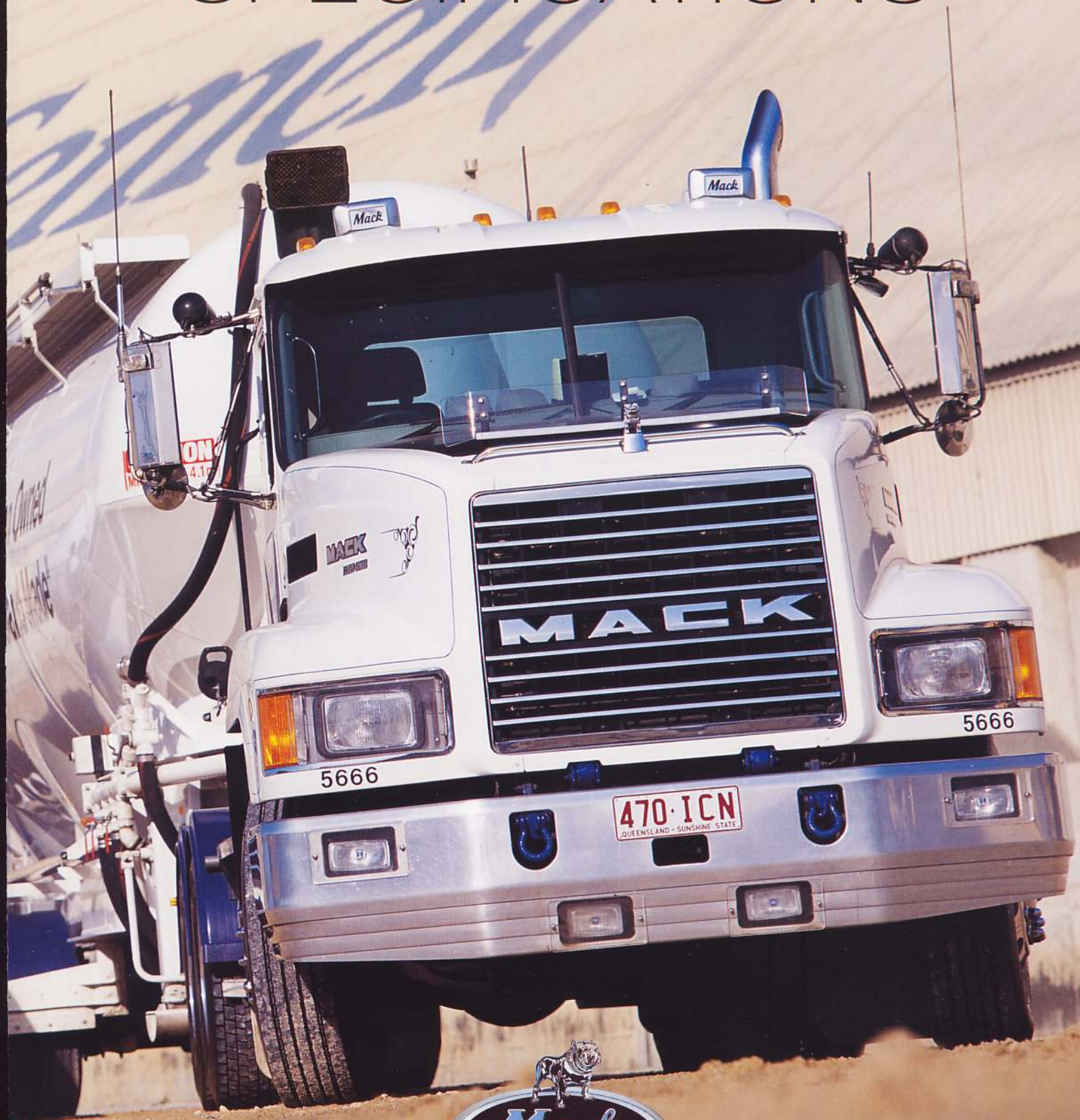

www.macktrucks.com.au

MACK - WE'RE ON THE MOVE

ENGINE & TRANSMISSION

ENGINE MODEL

MACK EA7-435 CCRS
12 litre, 6 cylinder
325 kW (435 hp) @ 1,800 rpm
2,115 Nm (1,560 lbs ft) torque @ 1,200 rpm

ENGINE BRAKE

Engine retarding power
313 Kw (420 hp) @ 2,100 rpm

AIR INTAKE & FILTER

DONALDSON 279 mm (11") Single dry type element with remote air intake at the rear of cab on LHS with dash mounted air restriction indicator

FILTERS

Oil : Two spin-on full flow disposables and one Centri-max centrifugal filter
Fuel : Two spin-on disposable
All engine mounted

AIR COMPRESSOR

16.5 cfm capacity

ALTERNATOR

12 Volt, 140 Amp

STARTER

12 Volt - electric starter motor
Key type start & stop, Idle timer activation switch

BATTERIES

Three 12 Volt

FAN

Heavy duty viscous drive with 8 blade metal fan

RADIATOR

7,406 cm² (1,148 in²) frontal area

EXHAUST

Single 127 mm (5") vertical exhaust and muffler with heat shield, post mounted on RHS
Standard height above ground : 3,400 mm
(Isolation mounted to back of sleeper when sleeper specified)

TRANSMISSION MODEL

EATON FULLER RTLO-16913A with oil cooler
13 speed overdrive transmission
Forward gears : 13 Reverse gears : 2
High : 0.73 Low : 12.31
Torque rating : 2,237 Nm (1,650 lbs ft)

CLUTCH

EATON 394 mm (15.5") Easy Pedal
Cable clutch control

FRONT & REAR AXLES

FRONT AXLE

MERITOR FG 941
Nominal capacity : 6,600 kg (14,520 lb)

FRONT SUSPENSION

Two 1,397 mm (55") long 3-leaf heavy duty parabolic springs with shock absorbers

FRONT BRAKES

MERITOR "Q Plus" 419 mm x 127 mm (16.5" x 5")
Front manual slack adjusters,
Type 20 brake boosters

STEERING GEAR

SHEPPARD M110 Ratio 23 : 1

REAR AXLES

DANA DSH40-P
Nominal capacity : 18,000 kg (40,000 lb)
Front mounted carriers, Ratio 4.33 : 1

REAR SUSPENSION

HENDRICKSON HAS-400 air suspension
Nominal capacity : 18,000 kg (40,000 lb)
(Hendrickson do not approve the HAS-400 for tipper use)

REAR BRAKES

DANA "ES" 419 mm x 178 mm (16.5" x 7")
Rear manual slack adjusters
Type 24 / 30 brake boosters
Dual line air with spring emergency brakes and emergency release hand control brake valve and tractor protection valve

DRIVELINE

SPICER 1810 HD main, 1710 interaxle

WHEELS

Front & Rear : Cast 6-spoke hubs
22.5" x 8.25" silver steel tubeless rims

TYRES

Front : MICHELIN XZE-2 11R22.5 - 16 ply
Rear : MICHELIN XDE-2 11R22.5 - 16 ply

CHASSIS

FRAME

Low alloy heat treated steel
258 mm x 88 mm x 8 mm (10.16")
Single Rail

WHEELBASE

4,293 mm (169") with turntable angles
Rear Overhang : 1,422 mm (56")

CAB MOUNTS

Front : Two metalastic pivot mounts
Rear : Air isolation with shock absorbers

FRONT BUMPER

Polished alloy bumper with air dam
(inner light provision)

AIR TANKS

Two steel tanks, one mounted under each battery box

FUEL TANKS

Two 360 litre alloy tanks with full length steps

BATTERY MOUNT

Single steel battery box with plastic cover mounted on LHS forward of the fuel tank

CAB

CA 65 Conventional galvanised steel cab,
S.M.C. bonnet and fenders with splash aprons
Bonnet tilts forward 75° with spring assist
Chrome grille and headlight bezels, External sunvisor

INTERIOR

Trim : Dark Warm Grey pleated vinyl
Dashboard : Wraparound with white face on black gauges
Floor : Black rubber mat
Sound system : PIONEER DEH 5450 Radio CD

INSTRUMENTS GAUGES - FULL

Speedometer / Odometer (Electronic)
Tachometer / Hourmeter (Electronic)
Voltmeter, Air pressure, Fuel level
Engine coolant & engine oil temperature
Manifold pressure, Air restriction indicator
Engine oil pressure, Brake air application
Transmission & rear axles oil temperature

CLIMATE CONTROL

Heater / Demister
Integral cab air conditioner with in-dash and dash mounted vents

COURTESY LAMPS

Door entry lighting.
Overhead roof console with driver and passenger courtesy lights

HEADLAMPS

Two rectangular lamps with hinged covers

HORNS

Air : Two rectangular single trumpet
Electric : Dual single tone

MARKER LAMPS

5 roof mounted amber lamps

MIRRORS

Heated 'West Coast' style with stainless steel arms and brackets
LH and RH spotter mirrors

BASE SPECIFICATION DATA 6 x 4

TARE WEIGHT	
FRONT	3,970 kg
REAR	3,240 kg
TOTAL	7,210 kg

Tare weights listed are with all fluids including 150L fuel and can vary plus or minus 2%

GROUND CL'ANCE	BBC
275 mm	2,855 mm

GVM	GCM
23,200 kg	50,000 kg

The GVM will vary according to the specified rear axle & suspension combination.

SEATS

Driver : Standard ISRI air ride driver's seat
Passenger : ISRI fixed cushion seat

STEERING WHEEL

Soft touch 457 mm (18") diameter
Adjustable tilt and telescopic steering column

WINDSHIELD WIPERS

Electric variable speed and intermittent with washer reservoir mounted under bonnet

PAINT

TYPE & COLOUR

Cab / Sleeper: Single non-metallic cab colour
Chassis : Single non-metallic chassis colour

TRAILER CONNECTIONS

Semi connections at rear of the cab

Air : Service and emergency with blanking plugs

Electrical : 12 Volt 7-pin female base

FACTORY OPTIONS

ENGINE MODEL

MACK EA7-470 CCRS
350kW (470 hp) @ 1800 rpm
2250 Nm (1,660 lbs ft) torque @ 1,200 rpm

AIR INTAKE

Remote air intake at the rear of cab on RHS
Under bonnet air intake

ALTERNATOR

12 Volt, 160 Amp

FAN

KYSOR DYNAIR on/off drive with 26" 9 blade nylon fan
(Mandatory with 470 Hp engine)

EXHAUST

Single 127 mm (5") vertical exhaust and muffler with heat shield post mounted on LHS (day cab only)
4,200 mm exhaust height optional
Underframe Exhaust

TRANSMISSIONS

EATON FULLER RTLO-16918B (18 speed)
EATON FULLER RTLO-18918B (18 speed)
EATON RTLO-18918 AUTOSHIFT (18 speed)
MACK T318LR (18 speed)
(Oil cooler fitted standard in all transmissions)

CLUTCH

EATON 'Easy Pedal' with VCTplus
EATON 'Solo' with VCTplus
EATON 'Solo' (< 50 Tonne GCM)

FRONT SUSPENSION

Heavy duty shock absorbers and bump stops
Two 1,397 mm (55") long multileaf springs with shock absorbers (option on double rail only)

FRONT BRAKES

MERITOR DX195 disc brakes
Front automatic slack adjusters

STEER WHEELS

10-stud (285 mm or 335 mm PCD) steel disc
ALCOA 10-stud (285 mm or 335 mm PCD) polished alloy disc
ALCOA 9" polished alloy disc (285 mm PCD)

STEER TYRES

MICHELIN XZE-2 295/80R22.5
MICHELIN XZY 295/80R22.5
MICHELIN XZE 275/70R22.5

REAR AXLES & SUSPENSIONS

MERITOR RT 40-145GP on HEND. HAS-461 (air)
MACK HAS 381/200 (air)
MACK NAS 462/200 (air)
DANA DS 462P on HENDRICKSON HAS-461 (air)
DANA DS 462P on NEWAY AD246 (air)
DANA DSH 40P on HENDRICKSON HAS-461 (air)
MERITOR RT 46-160GP on HEND. HAS-461 (air)
MERITOR RT 46-160GP on HEND. PRIMAAAX (air)
MERITOR RT 46-160GP on NEWAY AD246 (air)
MERITOR RT 46-160GP on MERITOR AC6S (6-rod)

DIFFERENTIAL LOCKS

Driver controlled cross wheel differential locks on both drive axles (only available on non-Mack axles)

REAR BRAKES

MERITOR DX225 disc brakes
(only with RT46-160 axles/HAS461 Susp)
Rear automatic slack adjusters
Type 30 / 30 brake boosters
WILLIAMS air ratio relay valve (not to be used for multiple trailer applications)
4-channel ABS anti-lock braking system

REAR AXLE RATIOS

Ratio 4.30 : 1 (RT 46-160GP)
Ratio 4.33 : 1 (DS 462P)
Ratio 4.35 : 1 (Mack only)
Ratio 4.56 : 1 (RT 46-160GP, DS 462P, DS 463P)
Ratio 4.63 : 1 (RT 40-145GP or DSH 40P)
Ratio 4.73 : 1 (Mack only)

LIGHTWEIGHT HUBS & DRUMS

Rear alloy hubs & centrifuse brake drums (only available with 285 mm PCD disc wheels)

REAR WHEELS

10-stud (285 mm or 335 mm PCD) steel disc
ALCOA 10-stud (285 mm or 335 mm PCD) polished alloy disc
(335 mm PCD wheels are not available on Mack rear axles)

DRIVE TYRES

MICHELIN XDY 11R22.5
MICHELIN XDE 275/70R22.5

FRAME

254 mm x 86 mm x 6 mm (10") + 6 mm Double rail
(Mandatory above 218" wheelbase and for GCM greater than 70 tonne)

TURNTABLE ANGLES

Full length turntable angles
(All wheelbases are available with or without turntable angles)

WHEELBASE (WB)

4,496 mm	(177")
4,724 mm	(186")
4,902 mm	(193")
5,029 mm	(198")
5,182 mm	(204")
5,334 mm	(210")
5,537 mm	(218")
5,690 mm	(224")

Other wheel bases on special request.

AFTERFRAME (RO)

1,700 mm (66.9") rigid rear overhang
(All chassis lengths can be specified with tapered ends)

BUMPER / BULLBAR

Delete polished alloy bumper with air dam
Polished alloy bumper with air dam (inner and outer light provision)
BOCAR fold down polished alloy bullbar

FUEL TANKS

Two 360 litre alloy tanks with LHS tank split (230L oil and 130 L fuel)
Two 510 litre alloy tanks
Four 360 litre alloy tanks
Two 510 litre and two 360 litre alloy tanks (Polished fuel tanks are available for all tank combinations)

BATTERY MOUNTS

Four 12 Volt batteries mounted in rear of sleeper (mandatory with sleeper)
Four 12 Volt batteries mounted behind fuel tanks on LHS (tipper style)
Four 12 Volt batteries mounted two each side inside chassis

INTERIOR

Medium warm grey vinyl trim
Woodgrain Dash Finish
Power Windows (LH and RH)
Power Windows (LH and RH) with Keyless Entry
Pioneer 6 stack CD player

DRIVER'S SEAT

Luxury ISRI air ride driver's seat with upper and lower lumbar support and fore/aft seat cushion adjustment

ISRI 6800/337 air ride driver's seat with cloth head rest, upper, side and lower lumbar support, oscillating base and fore/aft seat cushion adjustment

V.I.P (VEHICLE INFORMATION PROFILER)

In-dash integrated driver information display

SLEEPER COMPARTMENTS

SuperCab 810 mm Extended Flatroof
1,015 mm (40") Mid-rise PREMIUM sleeper
1,170 mm (46") Mid-rise PREMIUM sleeper
1,170 mm (46") High-rise PREMIUM sleeper
(All sleepers have 4 access doors and cab extenders)

FLEET-LINER FACTORY ACCESSORIES

Many factory fitted accessories (lights, radios, turntables, etc) are also available. All customers are encouraged to see their Authorised Dealer for full details.

REAR AXLE	RATIO	SUSPENSION*				
		HAS 400	HAS 461	PRIMAAX	NEWAY AD246	AC6S
DANA DSH 40-(P)	4.33:1	50,000 kg	50,000 kg	N/A	N/A	N/A
MERITOR RT 40-145GP	4.33:1	N/A	50,000 kg	N/A	N/A	N/A
MACK HAS 381/200	4.73:1	N/A	70,000 kg	N/A	N/A	N/A
MACK NAS 462/200	4.73:1	N/A	N/A	N/A	90,000 kg	N/A
DANA DS 462P	4.56:1	N/A	90,000 kg	N/A	90,000 kg	N/A
DANA DS 463P	4:56:1	N/A	N/A	N/A	N/A	N/A
MERITOR RT 46-160GP	4.56:1	N/A	90,000 kg	90,000 kg	90,000 kg	90,000 kg
UNLADEN RIDE HEIGHT (RH)#		1,036 mm	1,036 mm	1,044 mm	1,044 mm	1,080 mm

*Ratings shown are a guide to the maximum GCM's allowed for the nominated axle & suspension combinations, these can be restricted by the chassis rails (eg: Single rail 70 tonne maximum). Ratio shown is the lowest numerical ratio available for the nominated GCM.

• Application approvals must be obtained for all off-road operations and GCM's above 90,000kg.

Turntable angles are included in ride heights shown.

WHEELBASE (WB)	TURNTABLE SETTING DIST. (D) AHEAD OF CENTRE				MAXIMUM FUEL CAPACITY	TURNING CIRCLE (KERB TO KERB)
	Day Cab	Super Cab	40" Sleeper	46" Sleeper		
4,293 mm (169")	226 mm	N/A	N/A	N/A	2 X 510 litres	15.7 metres
4,496 mm (177")	428 mm	N/A	N/A	N/A	2 X 510 litres	16.2 metres
4,724 mm (186")	>450 mm	N/A	N/A	N/A	2 X 510 litres	16.9 metres
4,902 mm (193")	>450 mm	125mm	N/A	N/A	2 X 510 litres	17.4 metres
5,029 mm (198")	>450 mm	252mm	50 mm	N/A	4 X 360 litres	17.7 metres
5,182 mm (204")	>450 mm	405mm	200 mm	50 mm	2 X 510 & 2 X 360 litres**	18.2 metres
5,334 mm (210")	>450 mm	>450mm	352 mm	200 mm	2 X 510 & 2 X 360 litres**	18.6 metres
5,537 mm (218")	>450 mm	>450mm	>450 mm	402 mm	2 X 510 & 2 X 360 litres	19.2 metres
5,690 mm (224")	>450 mm	>450mm	>450 mm	>450 mm	2 X 510 & 2 X 360 litres	19.6 metres
5,994 mm (236")	>450 mm	>450mm	>450 mm	>450 mm	2 X 510 & 2 X 360 litres	20.4 metres
6,400 mm (252")	N/A	N/A	N/A	N/A	2 X 510 & 2 X 360 litres	21.6 metres
6,985 mm (275")	N/A	N/A	N/A	N/A	2 X 510 & 2 X 360 litres	23.2 metres

N/A indicates a trailer with a 4' 8" pin is unsuitable for this configuration.

* Distances shown are maximum with a 4' 8" pin while maintaining 8" swing clearance.

** Only with HAS or AC6 Suspensions (4 x 360 litres max. with all other suspensions).

Maximum fuel capacity is calculated with tool boxes forward of fuel tanks and Neway/Primaax suspensions fitted.

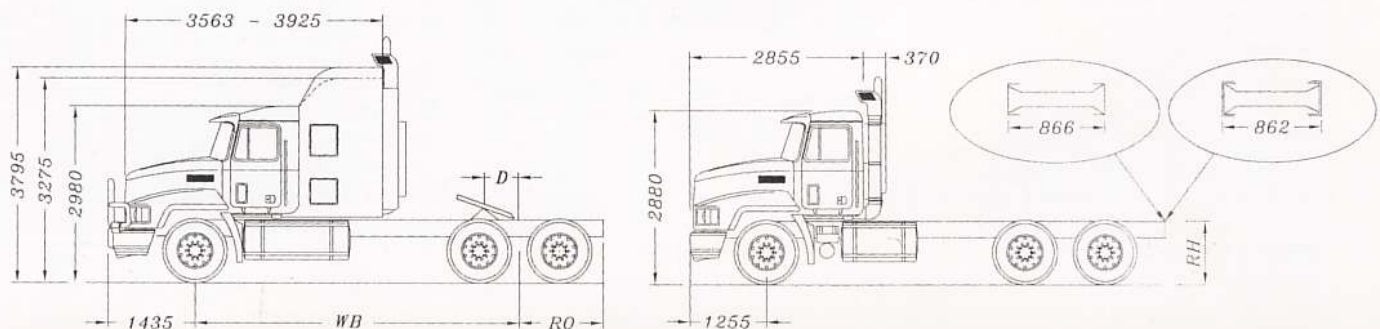

Mack Trucks Australia Pty Ltd
A.B.N. 41 009 719 582
20 Westgate Street, Wacol QLD 4076 AUSTRALIA
Ph: (07) 3718 3500 Fax: (07) 3718 3392

January 2004

www.macktrucks.com.au

The information in this brochure was current at the time of publication. Mack Trucks Australia Pty Ltd reserves the right to make changes in specifications, equipment, and design, or to discontinue models, options or extras without notice at any time.