

Section A



B-Model Mack Cabs

And You Thought All B's Were The Same!

This information came from sales literature I have, which does not cover every model. Any mistakes were free so don't complain; just let me know so corrections can be made.

102 with flush

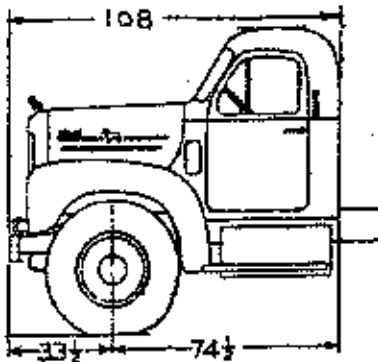

Most common cab

Flat Back Cab with standard nose
Used on B-20, 30, 31, 33, 37, 41, 42,
421, 422, 426, 4226, 43, 45, 47, 50, 53,
60, 61, 613, 615, 62, 63, 633, 68, 70

102 with extended bumper

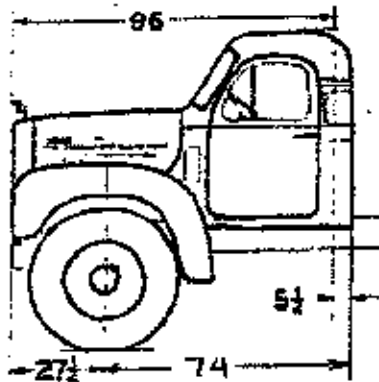

Contour Cab with standard nose
Used on B-42, 422, 60, 61, 68, 70, 615

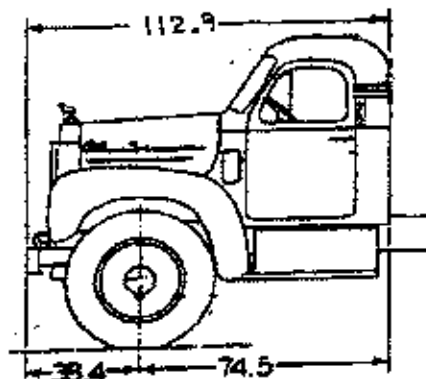

Flat Back Cab with external B-80's style
radiator and shutters.
Used on B-61 SE and B-613 SE (Export)

99 with extended bumper

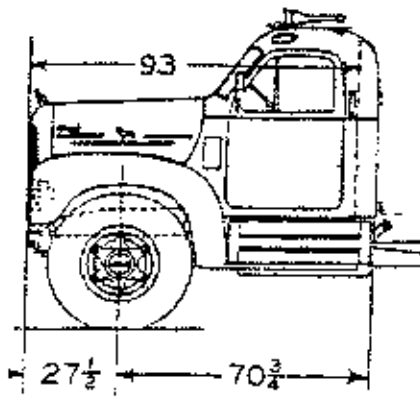

Contour Cab with short nose
Fenders are 3" shorter than standard
Used on B-44, 64, 65, 653

95 with flush bumper

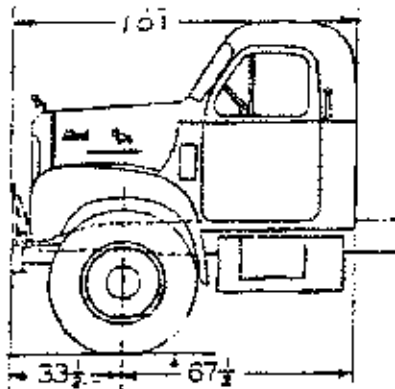

Flat Back Cab with shorter nose
Fenders are 7" shorter than standard
Notice the back of the fenders
Used on B-46, 462, 67, 673, 57

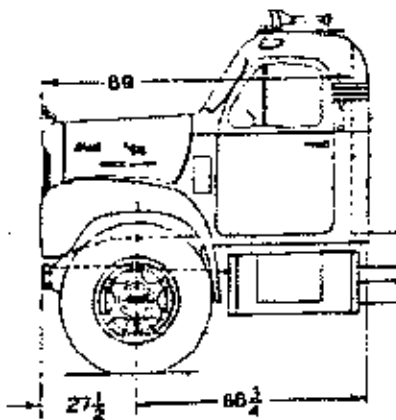

Contour Cab with shorter nose
Notice the same fenders as the cab
above
Used on B-66, 67, 673

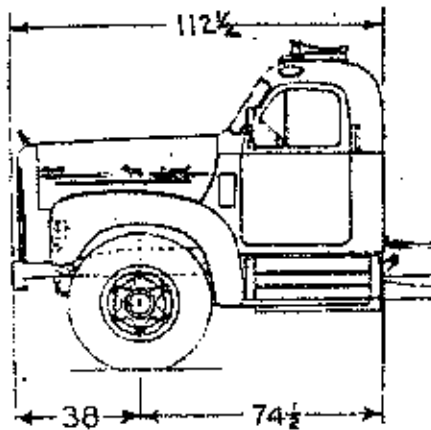

Flat Back Cab with long nose
 Notice the radiator extends past
 fenders
 Used on B-71

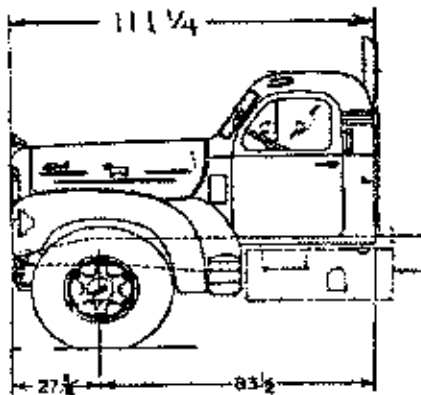

Flat Back Cab with long nose
 Notice the extensions between the
 fender and cowl leg.
 Used on B-72, 73, 733, 75, 753, 755,
 77, 773

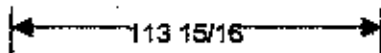

No Drawing



86 3/16

L cab with long nose
 Used on B-72, 73, 733, 75, 53,
 755, 77, 773

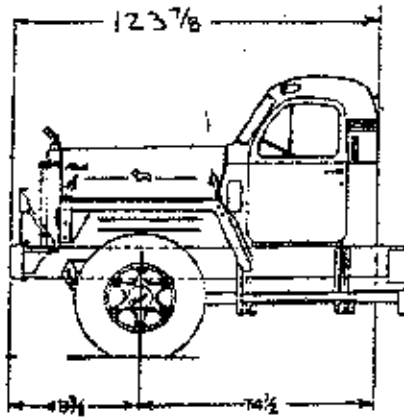

Flat Back Cab with long nose
Note military style fenders
Used on B-80, 81, 813, 8136, 815, 83,
833, 85, 853, 87, 873