

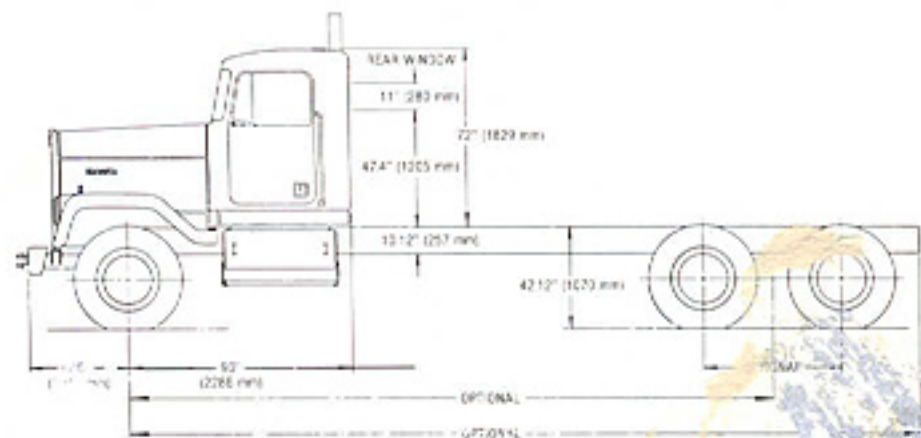

Scott McKenzie Collection

AIR CLEANERS	Single or dual-stage design
ELECTRICAL EQUIPMENT	Alternators 12VDC 105 amp (4) 6-volt batteries, group 4 type, Delco 1150 & 1200 Series, 12V 24-volt starting system Series parallel & transformer rectifier systems 12-volt lighting system
RADIATORS	1,400 sq. in. frontal areas Replaceable cores / removable top and bottom tanks / thermostatic shutters / aluminum folding hood with chrome grill / fabricated radiator with folding hood & drop-in side panels / fibreglass fenders / optional radiator guard
CLUTCHES	2-plate, dampened or rigid discs, 14 or 15 1/2 in. diam. (356 or 394 mm)
UNIT TRANSMISSIONS	Manual, automatic or power shift Allison — 5 and 6 speeds forward, 1 reverse Fuller — 5, 6, 8, 9, 10, 13 & 15 speeds forward, 1, 2, 3 speeds reverse Spicer — 5, 6, 7 & 12 speeds forward, 1, 2, 3 & 4 speeds reverse
DRIVELINES	Standard or heavy-duty dampened drivelines.
AUXILIARY TRANSMISSIONS	2 or 4 speed Spicer or Fuller models (Top-mounted power tower available on Spicer)
STEERING AXLES	"Reverse Elliot" design Rockwell 12,000, 13,200, 14,600 or 18,000 lbs. (5443, 6000, 6623, 8165 kg) with or without brakes; optional Ross or Sheppard power steering
DRIVING AXLES	Single or double reduction, single or two-speed Gear type: helical, hypoid, spiral bevel or planetary Variety of axle ratios available: Rockwell — 38,000 to 65,000 lb capacity (17,236 to 29,483 kg) Eaton — 38,000 to 65,000 lb capacity (17,236 to 29,483 kg) Clark — 80,000 lb capacity (36,287 kg)
SUSPENSION SELECTION	Varied types. Front: rolled eye, cast eye, slipper style Rear: multiple leaf spring & torque rods; walking beam with spring; rubber block

RADIAL TIRES	6.00 x 20 1/2 ply to 12.00 x 24-14 ply, tubeless or tube type
WHEELS	Spoke or disc type, steel construction
FUEL TANK	Single or multiple mountings, as required Size — 24.5 in. diameter steel (622 mm) 61, 75, 81, 94, 102 Imp. gallon capacity (279, 343, 370, 429, 463 litres)
CAB	Alum. and fibreglass construction. Full instrumentation, full head doors, safety glass, wheel fenders, liners, seat belts.
OPTIONAL ACCESSORIES	<i>Engine:</i> filters, single or dual exhausts, retarders, power take-offs <i>Outside:</i> steel fenders / high-mount fuel tank / front — rear tow hooks / hitches, trailer connections / 5th wheels / road and spot lighting packages / heated mirrors / hoesenna <i>Inside:</i> heavy duty heaters, defrosters, air-conditioning / radios / tape decks / optional seating <i>Safety:</i> air brake equipment / warning devices <i>Instruments:</i> recording tachometers and speedometers / pyrometers / air filter restriction gauges / clocks <i>Decor & Trim:</i> custom paint, VIT and Splendor Interiors
DIMENSIONS:	Height to top of cab — 113" (287 cm) 10.00 x 20 tires Width outside of fenders — 96" (2438 mm) Track varies with choice of axles and tires.



DEALER IMPRINT