

T908



 **KENWORTH**

**AUSTRALIAN MADE.
WORLD'S BEST.**



Legendary Kenworth cab appointments featuring luxurious colour co-ordinated trim and aircraft style instrumentation.

Large external air cleaners, with twin stage cyclonic action for maximum cleaning of intake air in outback conditions.

Choice of either single or two piece windscreen.

Stainless steel sunvisor.

Durable grille and exterior fittings.

Cooling packages specifically designed to meet Australia's toughest conditions.

Xenon globes in the headlights.

Optional 36" or 50" integrated sleeper boxes.

Large storage compartments each side under the sleeper bunk and in the centre, with optional rear access.

Remote keyless entry.

The widest range of specialist heavy duty rear axles.

Custom engineered fuel/oil tank packages available in round and rectangular configuration.

Long perforated steps allow plenty of choice on where to put your feet. Perforations allow mud to be scraped off and drop through.

Choice of Caterpillar or Cummins engines to meet the 2008 engine emission standards, up to 625 hp.

Stainless clad aluminium bumper or optional bullbar are factory fitted so that towing points are integrated into the chassis structure. FUPS device is also available.

Kenworth's long-bonneted T908 combines tough, traditional good looks with even tougher performance.

The T908 is ideal for applications ranging from general freight right through to logging, livestock and mining.

Whether in single trailer or multi-trailer road train configuration, on the highway or the roughest outback tracks, the T908 has been designed and built in Australia to deliver unmatched performance in the harshest possible conditions.



The best looking truck in Australia also has class leading performance on and off the highway.

Comfort

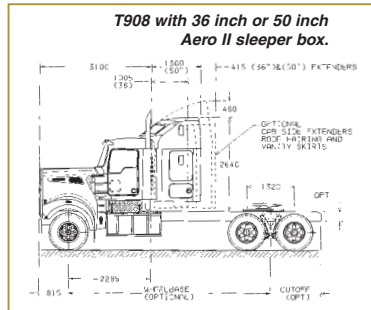
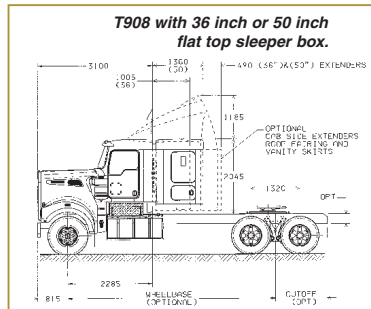
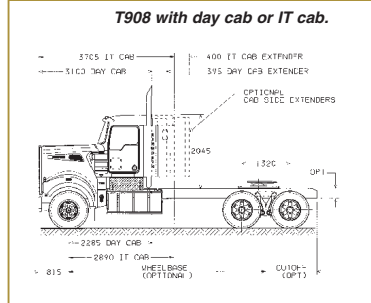
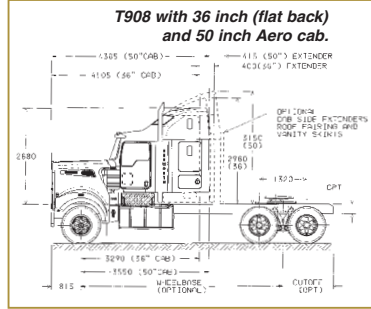

Driver comfort and safety

Classic styling has been teamed with the highest standards of driver comfort and safety in the T908 cab design.

The large one-piece curved windscreen (traditional two-piece screens are also optional) provides excellent all round visibility, and daylite doors with drop-down glass sections and safety.

An unobstructed view of gauges and easy access to vital switches and

controls are provided by the cleverly designed wraparound dash, enhancing driver comfort and minimising fatigue.

The overhead console features separate dimming and gives good access to the electrical switches, the CD AM/FM radio and storage compartment.

Headlights are safely actuated by toggle switches, and the engine brake and cruise control is conveniently mounted on the steering column.

A gentle red light under the dash illuminates the floor and reduces driver tunnel vision and fatigue.

Cool clean power

From 1 January 2008, all trucks manufactured for Australia have to meet the new ADR 83 standards for noise emissions and ADR80/02 standards for exhaust emissions.

Kenworth has responded to these challenges with tens of thousands of local engineering hours and in excess of 4 million test kilometers. We have met these new emission standards whilst still satisfying customer demand for continual improvements in power, fuel economy and productivity.



An extensive range of state-of-the-art engine options provides the T908 with up to 625hp and 2050ftlb torque.

The cooling system, assisted by the traditional high cabin configuration of the T908, is specifically designed for efficient engine operating temperature control, even under the stresses of extreme ambient temperature and multiple trailer load conditions on the roughest roads.

Sleeper options

The T908 can be optioned with any of Kenworth's range of traditional sleeper boxes, both flat and aerodyne roofs, in 36 or 50 inch configurations.

Integrated sleeper cabs that ride on airbag suspension for the ultimate in comfort can also be specified. The T908 IT cab features a 28 inch sleeper with flat roof, while the T908 Aero 36 and 50 inch units provide full standing headroom.





Design flexibility

The T908 hoods feature perforated, polished stainless steel grilles with chrome details either side of the bonnet.

Optional bull bars and aluminium wheels further enhance this truck's rugged good looks and functionality.

Optimising ride and stability as well as the traditional look, the forward set front axle of the T908 allows for the fitment of extra long-range fuel tanks.

A wide range of engine, transmission, axle and suspension options can be specified to arrive at your configuration for any application.

Form and function

Top quality design and engineering combined with performance, efficiency and an unsurpassed road presence make the Kenworth T908 one of the most satisfying trucks on the market to own and operate.

T908 Classic