

T904



AUSTRALIAN MADE. WORLD'S BEST.

“Designed, proven and manufactured in Australia, the T904 is built to handle the most demanding operating conditions both on and off highway, with the reliability that only Kenworth delivers.”



Classic Style

If you want a truck with classic looks and style, that is tough enough to stand up to harsh Australian conditions, then the T904 is the truck for you.

This truck has everything that comes to mind when you think about a traditional American-style long bonneted truck. The T904 has the rugged features that distinguish it from the pack.

As well as looking the part, the T904 has the versatility to operate in almost any application from logging to livestock, whether pulling a single trailer or a triple road train. The cabin sits high off the chassis to provide maximum cooling capacity for the highest horsepower engines.

Designed, proven and manufactured in Australia, the T904 is built to handle the most demanding operating conditions both on and off highway, with the reliability that only Kenworth delivers.

Renowned for their high resale value, the purchase of any Kenworth is a worthy investment.



Power to move a load.



Ideal for a wide range of applications.



At home on the road.



Driver Comfort and Style

The T904 dash layout delivers the best ergonomics for the professional driver. The driver enjoys all-round visibility with the large one-piece curved windscreen. (Two-piece windscreen is optional.)

The well-designed wrap-around dash gives the driver complete visibility of gauges unobscured by the steering wheel. All vital controls are easily within reach without the need for excessive movement or distraction.

Daylite doors, with drop-down glass section, provide sideways vision and increase safety. (Traditional-style doors are optional.)

The overhead console with separate dimming capabilities provides easier access to all electrical switches, airconditioning controls, CD AM/FM radio and storage compartment with door. To minimise the risk of accidental operation, headlights are operated by toggle switches. Engine management systems, if fitted, are positioned in the overhead console for clear visibility. Engine brake functions are steering column mounted for ease of handling.

A red light under the dash floods the floor with gentle light thereby reducing driver tunnel vision and fatigue.

Cool Power

The T904 is available with a complete range of engines from the major North American engine manufacturers, delivering up to 620hp with 2050lb/ft of torque. To achieve this high level of horsepower the cooling package is specifically designed to meet Australia's toughest conditions and applications where high temperatures, heavy loads and multiple trailer combinations are common – far higher requirements than for North American or European operations.

At Kenworth we can customise your truck to make it a unique vehicle purpose-built for your specific applications.



Wrap-around dash.



Daylite door with optional peeper window.



Wrap-around overhead console.



Optional twin bunks.



Engines up to 620hp.

“Undoubtedly one of the best looking trucks on the road, the T904 is a truck which others aspire to own.”



All the power you need to move your payload.



Sleeper Flexibility

The full range of Kenworth's traditional modular sleeper boxes – both flat and aerodyne, in 36 or 50 inch versions – is available with the T904.

In addition to these modular sleeper options, there is also a range of integrated sleeper cabs, all of which ride on an airbag suspension for even greater driver comfort. These are the T904 IT (features a 28 inch sleeper with flat roof), the T904 Aero 36 inch and the T904 Aero 50 inch (features a 50 inch sleeper with full standing headroom).

Design Flexibility

The T904 is available with an extensive choice of options.

The hood is fitted with a perforated, polished, stainless steel grille and chrome details either side of the bonnet. Optional chrome wrap-around scoops to protect air cleaner inlets are available from your dealer parts department.

Add to this the optional bull bar and aluminium wheels and the T904 stands well apart from other trucks on the road.

The front axle on the T904 is set forward adding to the classic look. This also provides excellent stability and ride and allows for multiple fuel tanks to be fitted (maximising fuel carrying capacity).

The latest options and horsepower ratings from North American engine manufacturers can be fitted to the T904 giving you the power you need to get the job done.

Matched with the latest in transmissions and rear axles the T904 can be ordered to exactly meet your operating needs.

A range of suspension packages are available including the Kenworth Airglide.



50 inch Aero cab.



36 inch Aero cab.



Day cab with optional roof fairing.

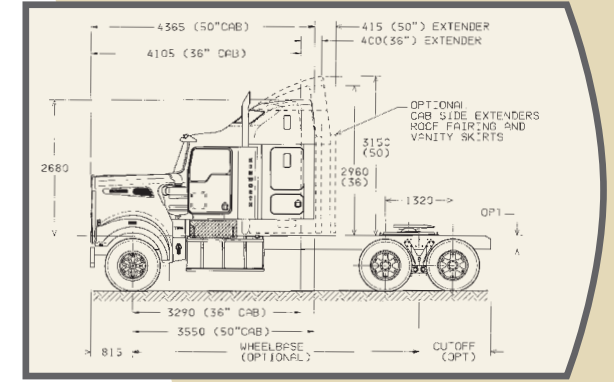

T904 with 36 inch (flat back) and 50 inch Aero cab.

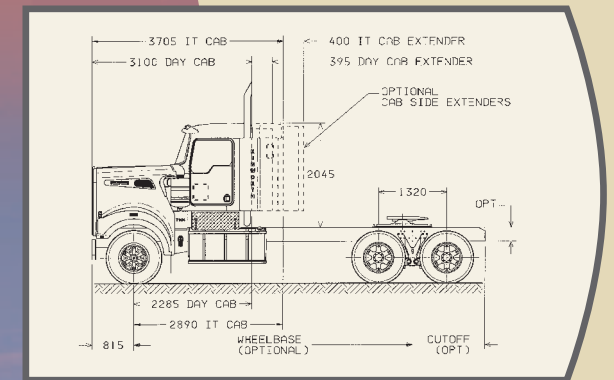

T904 with day cab or IT cab.

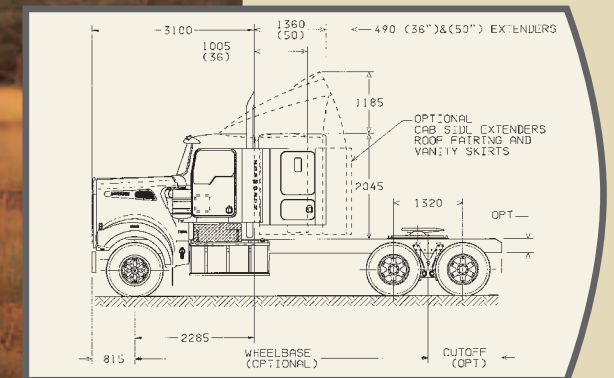

T904 with 36 inch or 50 inch flat top sleeper box.



Ergonomic dash layout.



Optional air cleaner wind deflector.



Optional peeper window.

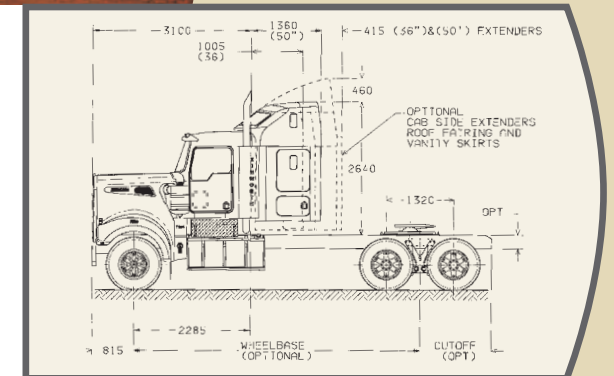

T904 with 36 inch or 50 inch Aero II sleeper box.





The Most Professional National Dealer Network

Every Kenworth truck is supported in the field by a comprehensive network of highly qualified dealers situated throughout Australia, New Zealand and Papua New Guinea. Each has a history of excellence in the heavy duty truck industry. An on-line computerised parts system ensures that Kenworth dealers provide a parts service to owners that is second to none. What's more, each dealership has a complete Bill of Material for every Kenworth truck built. So, when you want a part for your truck, there's no guesswork.

Made in Australia

Kenworth trucks are designed and manufactured in Australia to perform in some of the toughest and most demanding applications anywhere in the world. They are application-engineered to exacting standards, using the best in technology and componentry. On a whole-of-life cost basis, there are few trucks that come anywhere near Kenworth in helping to produce a better bottom line for your business.

www.kenworth.com.au



ABN 43 004 669 667



Quality
Endorsed
Company
ISO9001:2000
LIC-4676
Standards Australia

IMPORTANT

The vehicles shown in this brochure are for illustrative purposes only and may include some non-standard optional equipment. All weights and measurements should be regarded as approximate only. For full details please contact your Kenworth Dealer. In the interests of product improvement, Kenworth reserves the right to change these specifications without prior notice.

07052000

Plant History

- 1969: 28 acres of land purchased at Bayswater.
- 1970: A 56,000 sq/ft factory and office complex completed to produce trucks on a kit assembly basis.
- 1971: The first Australian-made Kenworth – a K100C built and delivered to Comet Overnight Transport.
- 1978: The plant expanded to 100,000 sq/ft to keep up with production demand.
- 1986: PACCAR Parts warehouse and distribution centre built at Bayswater, comprising 51,000 sq/ft.
- 1996: The production plant expanded a further 30,000 sq/ft, after a dynamometer facility ('93), training facilities ('88) and a staff canteen ('88) were added.
- 1998: PACCAR Parts warehouse extended by 52,000 sq/ft to over 100,000 sq/ft.

