

# T658



**AUSTRALIAN MADE. WORLD'S BEST.**

# BUILT TOUGH FOR A BIG COUNTRY

## PURPOSE BUILT FOR THE BIGGEST TASKS

The Kenworth T658 is a big strong truck purpose built for big tough Australian jobs. This is the truck of choice for heavy long hauls, be it the smooth highway or the roughest outback tracks, long, reliable service in the most extreme operating conditions known to Australasia and delivered with the highest levels of drive comfort and safety.

The T658 has the versatility and power to operate in applications ranging from general freight to logging, mining or livestock haulage, on or off the highway in single or multiple configurations. Supreme performance combined with great comfort and safety make the T658 one of the most versatile trucks on or off the road.



AUSTRALIAN MADE. WORLD'S BEST.

# UP CLOSE & TECHNICAL

## ENGINEERED FROM THE GROUND UP FOR ULTIMATE STRENGTH AND DURABILITY

The Kenworth T658 has been designed with demanding on or off-highway operating conditions particularly in mind. The front axle has been set back for increased manoeuvrability and a tight turning circle, as is required for logging and similar applications. The high mounted cab is set back clear of the engine to give excellent access for easy maintenance and servicing in remote conditions.

Mounting the cab higher also provides more flexibility in frame layout. Batteries can be located under the cab allowing a shorter wheelbase or longer range fuel tanks, or can be frame-mounted allowing space for tool boxes under the cab.

## T658'S ARE TAILOR MADE TO YOUR APPLICATION

We look carefully at your specific application and performance requirements and put together the best possible combination of chassis, engine, transmission, driveline and cab layout to deliver the performance you want.

Through application engineering we can build in more features and clever design solutions to suit your needs. Application engineering means we can meet your special requirements at the design/specification phase and install the right components on the assembly line to give life-long performance and reliability.

## CHASSIS FRAME LAYOUT

Kenworth trucks can be built to virtually any wheelbase with components mounted onto the frame to suit your individual needs.

The strength of each frame is enhanced by locating the various parts so that loads are evenly spread and fuel tank capacity can be maximised. Battery boxes are positioned to minimise the length of battery cables for ease of starting and to ensure the batteries are subjected to the lowest possible shock loads.

## FUEL TANKS

At Kenworth trucks we design our own fuel and oil tanks. Engineering fuel tanks specifically for an application can deliver cost savings by setting up a truck so it can refuel where you want it to. Aluminium tanks are standard for weight saving, or you can select steel tanks for severe applications.

All these features are examples of Kenworth's attention to design, function and quality.

## T658 with or without base sleeper

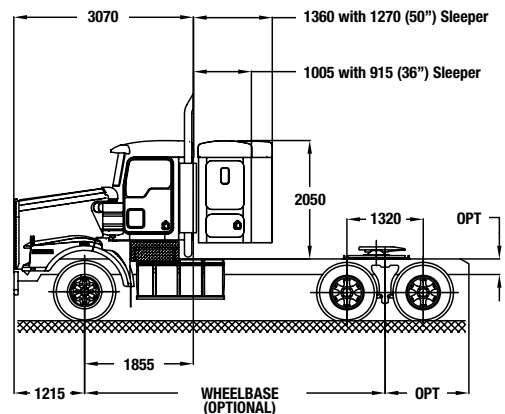

## T658 with Aero II Sleeper

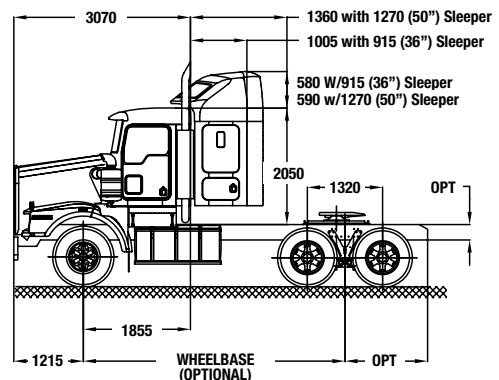

## T658 with Aero II roof package

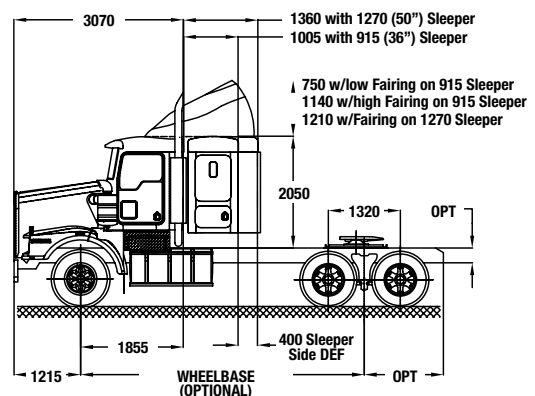

- Large storage compartments each side under the sleeper bunk and in the centre, with optional rear access.

- Choice of 36" or 50" modular sleeper boxes mounted to the chassis or suspended sub-frame.

- Legendary Kenworth cab appointments featuring luxurious colour co-ordinated trim and aircraft style instrumentation.

- Large external air cleaners, with twin stage cyclonic action for maximum cleaning of intake air in outback conditions.

- Remote keyless entry.

- Cummins engines to meet requirements up to 600/615 hp and 2050 lbft.

- Sloping bonnet profile offering great all round visibility.

- Optional stainless steel sunvisor.

- Stainless clad aluminium bumper or optional FUPS bullbar are factory fitted so that towing points are integrated into the chassis structure. An aluminium FUPS Texas' style bumper is also available.

- Durable grille and exterior fittings.



- The widest range of specialist heavy duty rear axles to best suit your needs.

- Custom engineered steel or alloy fuel/oil tanks available in round or rectangular configuration to maximise fuel capacity.

- Long perforated steps allow plenty of choice on where to put your feet. Perforations allow mud to be scraped off and drop through.

- Cooling packages specifically designed to meet Australia's toughest conditions for class leading durability and reliability.

**AUSTRALIAN MADE. WORLD'S BEST.**

# THE COMMAND CENTRE

## DRIVER COMFORT AND SAFETY

A lot of care has been taken to design the T658 cab to provide the highest levels of driver comfort and safety in the wide variety of applications in which this truck will be operating. The end result is higher operating efficiency.

The large two piece windscreen offers a commanding view over the sloping hood that offers excellent short distance forward vision in confined spaces and Daylite doors with drop down glass sections provide improved side vision. Traditional doors are available as an option.

As well as the comprehensive standard gauge layout, you can choose from a wide range of optional gauges and instruments to meet your individual needs.

State-of-the-art cab comforts are further enhanced by improved airflow from the high cabin design reducing heat transfer to the cab. Long front springs provide the smoothest possible ride in all conditions, increasing safety and efficiency.

The T658 can be optioned with Kenworth's range of modular sleepers available in 36" or 50".



AUSTRALIAN MADE. WORLD'S BEST.

# TOUGH AS NAILS

## EASY TO SERVICE

Kenworth's T658 trucks are built tough and strong for the most rugged and remote applications. When it comes to servicing in any locations the T658 high mounted cab is designed to sit back clear of the engine so that it affords excellent access for easy maintenance.

With extremes of loads, temperatures and humidity, Australia has some of the toughest operating conditions in the world, so we have been careful to design and test all cooling components in Australia. This is why the class leading cooling package is designed to reduce fan on time in even the harshest Australian conditions.

## REAR AXLE SUSPENSIONS

All Kenworth suspensions are of the highest quality with proven performance and reliability.

A suspension unique to Kenworth is the eight air bag AIRGLIDE. This suspension is excellent for ride and handling across many applications, ranging from white goods and produce to fuel haul.

For mining, roadtrain and some off highway applications, Kenworth offer the tough durable and low maintenance six rod Kenworth KW6-60A suspension renowned for its legendary longevity in the toughest conditions.



## DRIVETRAIN

To get power to the ground, we offer a selection of proven drivetrain components for the T658 from the best suppliers available including transmissions from Eaton, coupled with drive axles from Meritor and Dana.

## ATTENTION TO DETAIL

At Kenworth even the smallest component of the T658 has to be the best or it is not fitted.

Many of our trucks operate in extreme levels of dust and dirt. Where possible we double clamp all piping on the clean side of the air intake system to maximise the clean air protection.

The electrical system is one of the most important parts of any truck and that is why we have independent circuits to each high beam headlight and there are screw on terminals on circuit breakers and gauge senders.

Collectively these sorts of details deliver big improvements in quality and reliability, longer life and higher standards of safety.



Piping bundle tied every 150mm.



Double clamping provides extra engine protection.



Screw on terminals don't shake loose.



Spring loaded constant torque clamps stay tight.

AUSTRALIAN MADE. WORLD'S BEST.



## **THE MOST PROFESSIONAL DEALER NETWORK**

Every Kenworth truck is supported in the field by an extensive network of highly qualified dealers throughout Australia, New Zealand and Papua New Guinea. Each dealer has a history of excellence in the heavy duty truck industry.

Kenworth's on-line parts system provides owners with unmatched service. And each dealership has a complete Bill of Material for every Kenworth truck built, so when you want a part for your truck, there's no guesswork.



## **MADE IN AUSTRALIA**

Kenworth trucks are designed and manufactured in Australia to perform in some of the toughest and most demanding applications found anywhere in the world. They are application engineered to exacting standards, using the best technology and componentry.

On a whole-of-life cost basis, there are few trucks that can approach Kenworth in helping to produce a better bottom line for your business.



## **AN ENVIABLE RECORD**

From its beginning in Bayswater, Victoria in 1971, Kenworth's Australian operations have developed into a world class design, development, manufacturing and testing facility incorporating advanced training services and its sophisticated PACCAR Parts warehouse and distribution centre.

With around 40,000 Australian made trucks delivered, Kenworth Australia provides products and services to the transport sector that are the envy of the industry worldwide.

**AUSTRALIAN MADE. WORLD'S BEST.**

## THE BEST DEALER NETWORK

Kenworth has built an extensive truck dealer network across Australia that is renowned for its professionalism and excellence in the heavy duty truck industry. The Kenworth dealer network also includes highly qualified dealers in New Zealand and Papua New Guinea.



# PACCAR

For more information contact your local Kenworth Dealer  
or go to [www.kenworth.com.au](http://www.kenworth.com.au)

IMPORTANT: The vehicles shown in this brochure are for illustrative purposes only and may include some non-standard optioned equipment. All weights and measurements should be regarded as approximate only. For full details contact your Kenworth Dealer. In the interests of product improvement, Kenworth reserves the right to change these specifications without prior notice.

PACCAR Australia Pty Ltd, 64 Canterbury Road, Bayswater, Victoria 3153  
Telephone (03) 9721 1500 Facsimile: (03) 9720 4144

**[www.kenworth.com.au](http://www.kenworth.com.au)**



**PACCAR  
FINANCIAL**

**AUSTRALIAN MADE. WORLD'S BEST.**