

DEFINING TOMORROW

T609



● T609

With its sleek new aerodynamic styling and improved driving environment, the T609 continues to provide you with the power to haul the biggest payloads, efficiently and in total comfort. The T609 is primarily suited to on-highway application and offers a range of engine options up to 615 peak horsepower, with excellent cooling capacity and all the in cab luxuries. The T609 is well suited to multiple trailer combinations including B-Double and road trains. The T609 stands out for outright versatility and road presence.



● ADR 80/03 - THE NEW AUSTRALIAN EMISSIONS STANDARD

For the T609 the emission solution employed to meet ADR 80/03 in the 2011 model range powered by Cummins ISX and Signature engines is cooled Exhaust Gas Recirculation (EGR).

Kenworth is introducing a Cummins Particulate Filter as part of the engine package. The Cummins Particulate Filter, which replaces the existing vehicle muffler, reduces particulate emissions by 90% from ADR80/02 is designed to last the life of the engine.

Kenworth's application engineering process has delivered an optimised solution that integrates EGR seamlessly across the high horsepower engine options. So as well as being highly efficient and low maintenance the EGR emission solution has little or no impact on payload and efficiency. Kenworth customers get the emission compliance they need with the proven performance and reliability of engines they know and trust – all with the back up of our renowned local design and manufacturing capability and Australia wide support network.

● EBSS - ELECTRONIC BRAKE SAFETY SYSTEM

At Kenworth, safety has always been a paramount consideration, and we continue to invest heavily in developing a safer working environment for road transport operators and other road users. All 2011 new model Kenworth's are available with the latest Kenworth EBSS Safety Package. EBSS incorporates a variety of safety features including ABS, Drag Torque Control, Traction Control and ESP.

Kenworth EBSS has been designed to provide a class leading and reliable system for Australasia's unique road conditions and applications, and deliver better peace of mind for all road users. To learn more about these safety systems visit www.kenworth.com.au

NEW DOORS



NEW AERO STYLING



NEW LARGE GRILLE



T609 DAY CAB

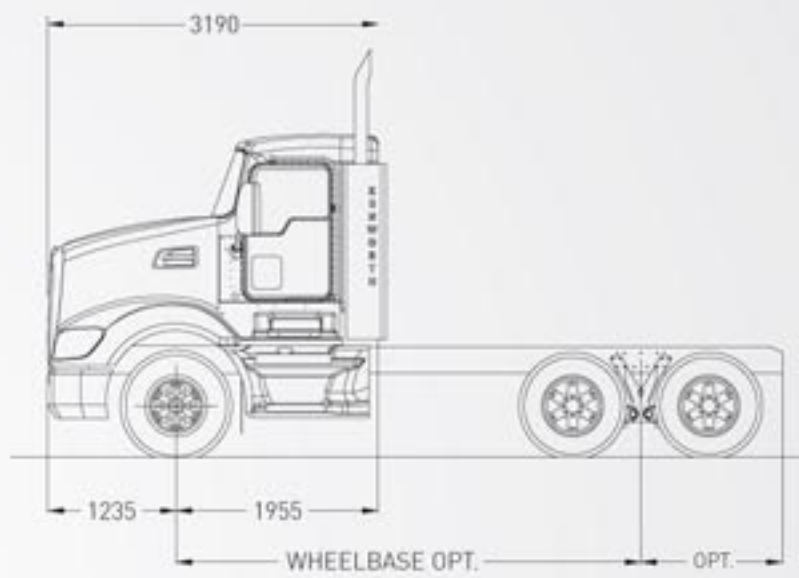

T609 28" IT

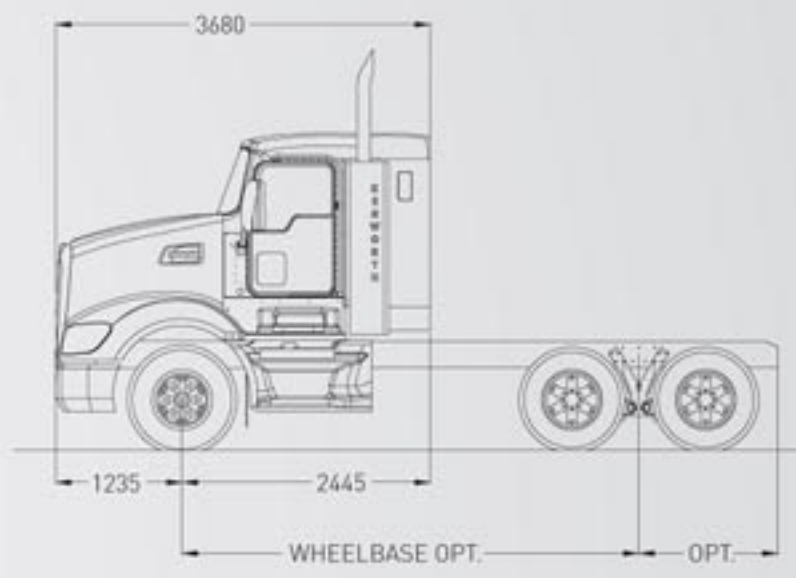

T609 36" RB

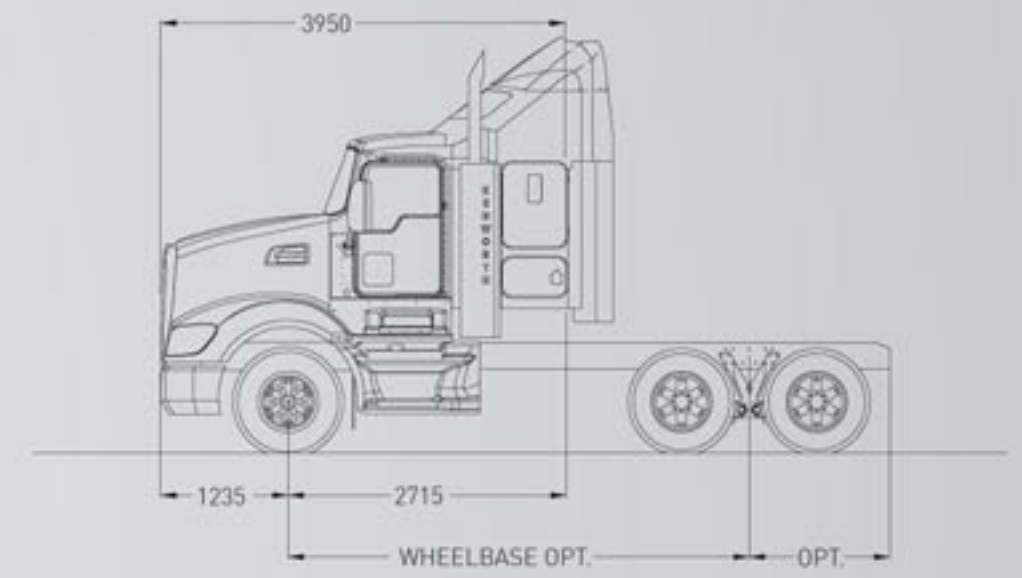

T609 36" FB

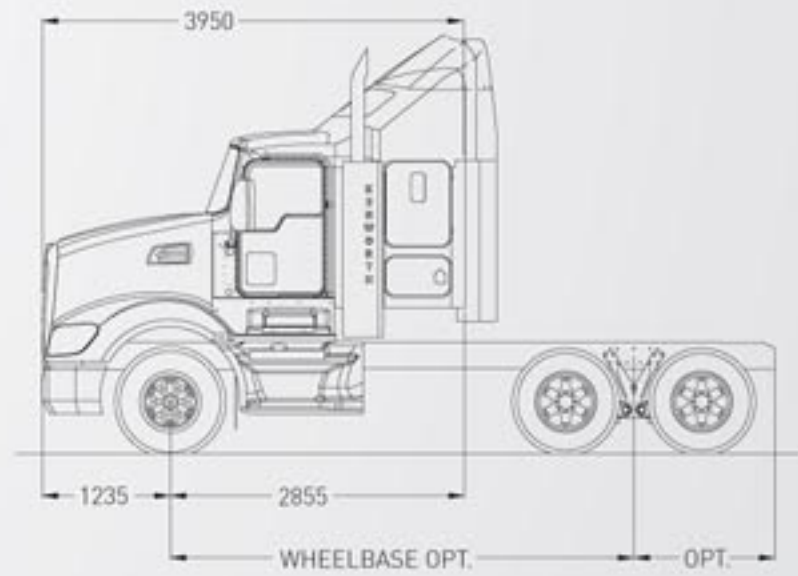

T609 50"

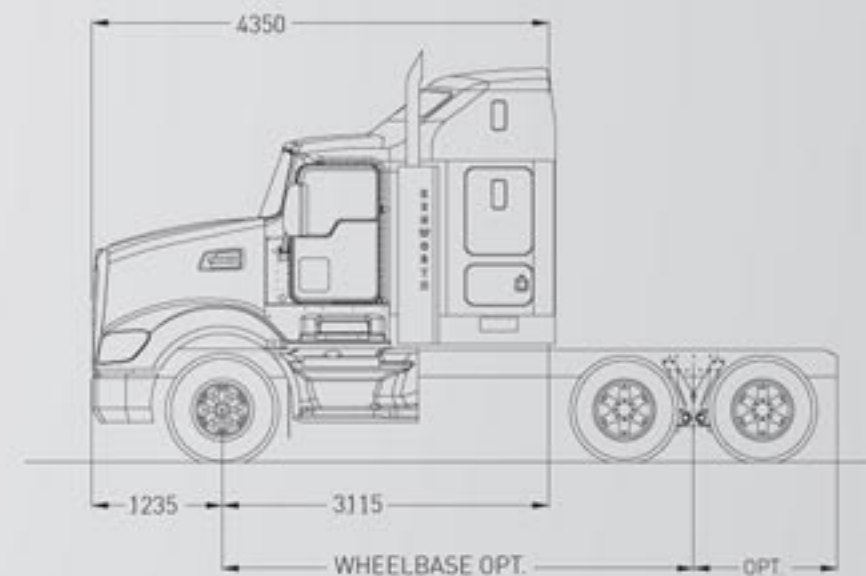

MAIN SPECIFICATIONS AND OPTIONS

CONFIGURATION

- 6X4 **standard**
- 8X4 **optional**

KITS

- FUEL HAUL & GAS HAUL **optional**

ENGINE

- ISX EGR 485HP @ 1650LBFT TORQUE **standard**
- ISX EGR 485HP @ 1850LBFT TORQUE **optional**
- ISX EGR 500HP @ 1850LBFT TORQUE **optional**
- ISX EGR 525HP @ 1850LBFT TORQUE **optional**
- ISX EGR 550HP @ 1850LBFT TORQUE **optional**
- ISX EGR 600HP @ 1850LBFT TORQUE **optional**
- SIGNATURE 600HP @ 2050LBFT TORQUE **optional**

EXHAUST

- DPF MOUNTED UNDER CAB RIGHT HAND FORWARD **standard**
- DPF MOUNTED UNDER CHASSIS **optional**

AIR CLEANER

- DONALDSON 2540 AIR CLEANER MOUNTED UNDER HOOD **standard**

TRANSMISSION

- EATON RTL016918B **standard**
- Up to EATON RTL022918B **optional**
- Up to EATON RTL018913A **optional**
- Up to EATON RTL022918A-AS3 **optional**

ULTRASHIFT PLUS OPTIONS

- FO-16E318B-MXP **optional**
- FO-18E318B-MXP **optional**
- FO-20E318B-MXP **optional**
- FO-22E318B-MXP **optional**

FRONT AXLE

- DANA E-1462I **standard**
- MERITOR FG941 **optional**
- MERITOR MFS73 **optional**

REAR AXLE

- DANA DSH40P **standard**
- DANA D46-170 **optional**
- DANA D50-170 **optional**
- DANA D52-190 **optional**
- DANA D52-190 WITH LAZY AXLE (8X4 ONLY) **optional**
- MERITOR RT40-145 **optional**
- MERITOR RT46-160 **optional**
- MERITOR RT50 - 160 **optional**
- MERITOR RT52-185 **optional**
- MERITOR RT52-185 WITH LAZY AXLE (8X4 ONLY) **optional**

REAR SUSPENSION

- KENWORTH AIRGLIDE 400 **standard**
- KENWORTH AIRGLIDE 460 **optional**
- KENWORTH KW6-60A **optional**
- NEWAY AD246/10 **optional**
- NEWAY AD3691/10 (WITH 8X4 ONLY) **optional**

BRAKES

- DRUM **standard**
- DISC **optional**

WHEELS

- 6 SPOKE **standard**
- ALCOA 10 STUD **optional**

SLEEPER

- 28" IT **optional**
- 36" AERO RECESSED BACK **optional**
- 36" AERO FLAT BACK **optional**
- 36" MID ROOF SLEEPER **optional**
- 50" AERO FLAT BACK **optional**

FUEL TANKS

- 450L 625MM DIA FUEL TANK LEFT HAND FORWARD **standard**
- RANGE OF PACKAGES AVAILABLE **optional**

PAINT

- SINGLE COLOUR TO CAB **standard**
- UP TO 3 COLOURS 6 BREAKS **optional**

GCM

- 90 TONNE LIMIT*



* higher rating subject to application approval

THE BEST DEALER NETWORK

Kenworth has built an extensive truck dealer network across Australia that is renowned for its professionalism and excellence in the heavy duty truck industry. The Kenworth dealer network also includes highly qualified dealers in New Zealand and Papua New Guinea.



For more information contact your local Kenworth Dealer or go to www.kenworth.com.au

IMPORTANT: The vehicles shown in this brochure are for illustrative purposes only and may include some non-standard optional equipment. All weights and measurements should be regarded as approximate only. For full details contact your Kenworth Dealer. In the interests of product improvement, Kenworth reserves the right to change these specifications without prior notice.

PACCAR Australia Pty Ltd,
64 Canterbury Road, Bayswater, Victoria 3153

Telephone (03) 9721 1500
Facsimile: (03) 9720 4144

PACCAR



PACCAR FINANCIAL