

DEFINING TOMORROW

T409SAR



● T409SAR

The T409SAR is specifically designed to provide maximum payload under Australian regulations for 19m B-Double and most 19m Quad Dog applications. It also fits the 26m envelope B-Double with 36" sleeper. Reflecting its function as a tough workhorse, the T409SAR features power up to 580 peak horsepower under the classic Kenworth flat grille and hood.



● ADR 80/03 - THE NEW AUSTRALIAN EMISSIONS STANDARD

For the T409SAR the emission solution employed to meet ADR 80/03 in the 2011 model range powered by Cummins ISX is cooled Exhaust Gas Recirculation (EGR).

Kenworth is introducing a Cummins Particulate Filter as part of the engine package. The Cummins Particulate Filter, which replaces the existing vehicle muffler, reduces particulate emissions by 90% from ADR80/02 and is designed to last the life of the engine.

Kenworth's application engineering process has delivered an optimized solution that integrates EGR seamlessly across the high horsepower engine options. So as well as being highly efficient and low maintenance the EGR emission solution has little or no impact on payload and efficiency. Kenworth customers get the emission compliance they need with the proven performance and reliability of engines they know and trust – all with the back up of our renowned local design and manufacturing capability and Australia wide support network.

● EBSS - ELECTRONIC BRAKE SAFETY SYSTEM

At Kenworth, safety has always been a paramount consideration, and we continue to invest heavily in developing a safer working environment for road transport operators and other road users. All 2011 new model Kenworth's will be available with the latest Kenworth EBSS Safety Package. EBSS incorporates a variety of safety features including ABS, Drag Torque Control, Traction Control and ESP.

Kenworth EBSS has been designed to provide a class leading and reliable system for Australasia's unique road conditions and applications, and deliver better peace of mind for all road users. To learn more about these safety systems visit www.kenworth.com.au

NEW FEATURES

The new T409SAR Kenworth features a wide range of important enhancements- from the significant driver environment improvements to the new trim colours and additional safety features. New doors have been introduced with electric windows as standard, wider more comfortable arm rests, new heavy duty steel key and improved Heater, Ventilation and Air Conditioner Units to keep you warmer in winter and cooler in summer.

The 2011 range also sees the introduction of the new Eaton "Ultrashift plus" automated transmissions. This two-pedal transmission delivers significant improvements in performance, superior acceleration and low speed manoeuvrability with its revolutionary Electronic Clutch Actuation (ECA).

NEW DOORS



T409SAR 28" IT SLEEPER

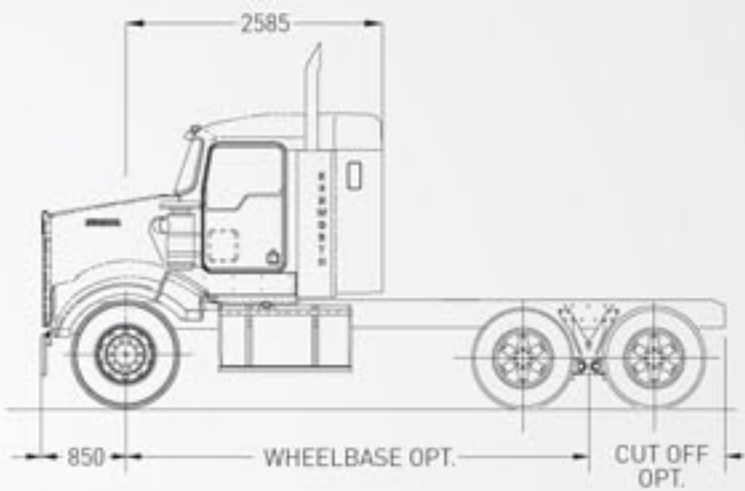

T409SAR 36" SLEEPER
MID ROOF RECESSED BACK

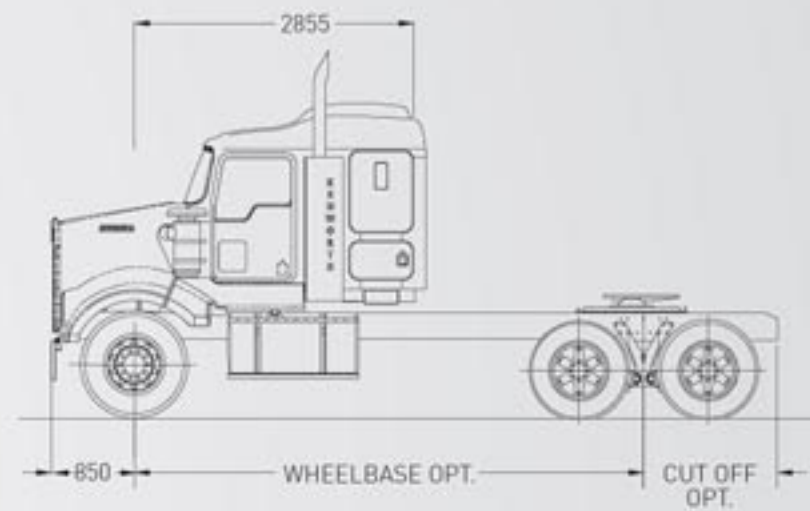

T409SAR 36" SLEEPER
FLAT BACK

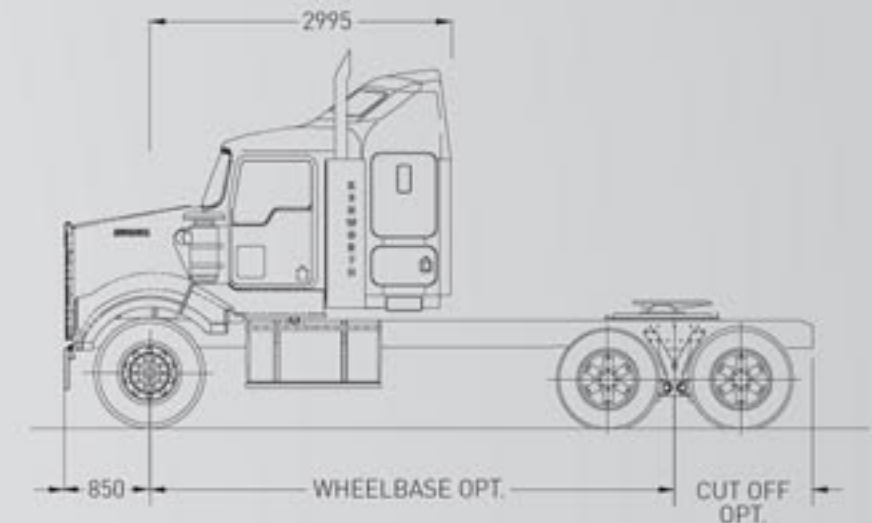

T409SAR DAY CAB

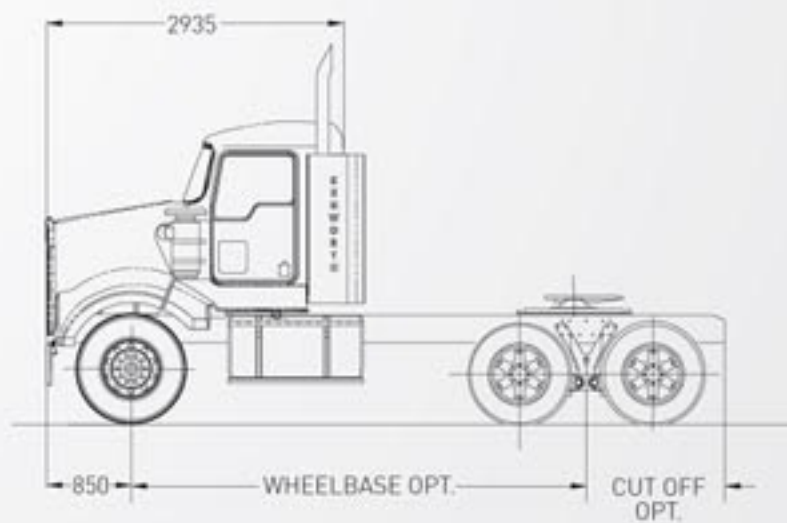

T409SAR 36" SLEEPER
RECESSED BACK

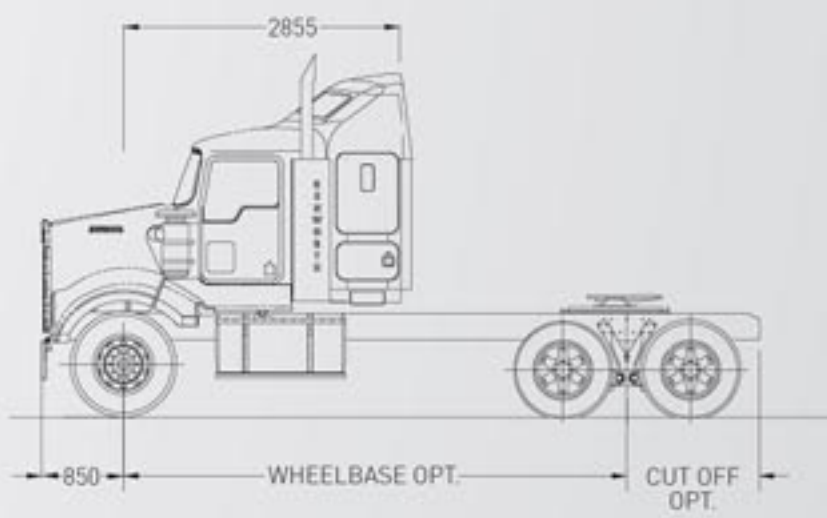

T409SAR 50" SLEEPER

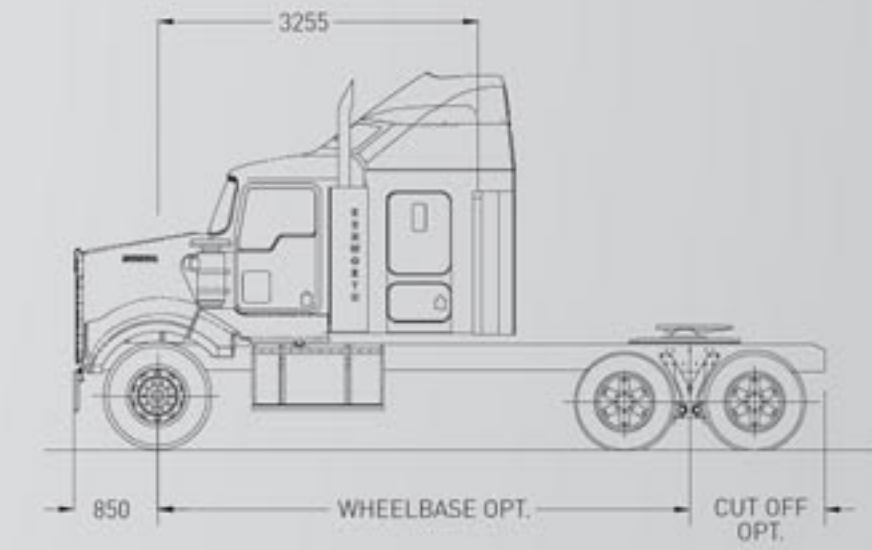

MAIN SPECIFICATIONS AND OPTIONS

CONFIGURATION

- 6X4 **standard**

KITS

- FUEL HAUL & GAS HAUL **optional**

ENGINE

- ISX EGR 485HP @ 1650 LBFT TORQUE **standard**
- ISX EGR 485HP @ 1850 LBFT TORQUE **optional**
- ISX EGR 500HP @ 1850 LBFT TORQUE **optional**
- ISX EGR 525HP @ 1850 LBFT TORQUE **optional**
- ISX EGR 550HP @ 1850 LBFT TORQUE **optional**

EXHAUST

- DPF MOUNTED UNDER CAB RIGHT HAND FORWARD WITH SINGLE OR DUAL TAIL PIPES
- DPF MOUNTED IN CHASSIS WITH SINGLE OR DUAL TAIL PIPES

AIR CLEANER

- DONALDSON 2504 AIR CLEANER MOUNTED UNDER HOOD **standard**
- DUAL DONALDSON ERA COWL MOUNTED
- STAINLESS STEEL COWL MOUNTED **optional**

TRANSMISSION

- EATON RTL016918B **standard**
- Up to EATON RTL020918B **optional**
- Up to EATON RTL018913A **optional**
- Up to EATON RTL020918A-AS3 **optional**

ULTRASHIFT PLUS

- FO-16E318B-MXP **optional**
- FO-18E318B-MXP **optional**
- FO-20E318B-MXP **optional**

FRONT AXLE

- DANA E-14621 **standard**
- MERITOR FG941 **optional**
- MERITOR MFS73 **optional**

REAR AXLE

- DANA DSH40P **standard**
- DANA D46-170 **optional**
- DANA D50 - 170 **optional**
- DANA D52 - 190 **optional**
- MERITOR RT40-145 **optional**
- MERITOR RT46-160 **optional**
- MERITOR RT50 - 160 **optional**
- MERITOR RT52 - 185 **optional**

REAR SUSPENSION

- KENWORTH AIRGLIDE 400 **standard**
- KENWORTH AIRGLIDE 460 **optional**
- KENWORTH KW6-60A **optional**
- NEWAY AD246/10 **optional**

BRAKES

- DRUM **standard**
- DISC **optional**

WHEELS

- 6 SPOKE **standard**
- ALCOA 10 STUD **optional**

SLEEPER

- 28" IT **optional**
- 36" AERO RECESSED BACK **optional**
- 36" AERO FLAT BACK **optional**
- 36" MID ROOF SLEEPER **optional**
- 50" AERO FLAT BACK **optional**

FUEL TANKS

- 400L 625MM DIA FUEL TANK LEFT HAND FORWARD **standard**
- RANGE OF PACKAGES AVAILABLE IN ROUND AND RECTANGULAR TANKS **optional**

PAINT

- SINGLE COLOUR TO CAB **standard**
- UP TO 3 COLOURS 6 BREAKS **optional**

GCM

- 80 TONNE LIMIT

THE BEST DEALER NETWORK

Kenworth has built an extensive truck dealer network across Australia that is renowned for its professionalism and excellence in the heavy duty truck industry. The Kenworth dealer network also includes highly qualified dealers in New Zealand and Papua New Guinea.



For more information contact your local Kenworth Dealer or go to www.kenworth.com.au

IMPORTANT: The vehicles shown in this brochure are for illustrative purposes only and may include some non-standard optional equipment. All weights and measurements should be regarded as approximate only. For full details contact your Kenworth Dealer. In the interests of product improvement, Kenworth reserves the right to change these specifications without prior notice.

PACCAR Australia Pty Ltd,
64 Canterbury Road, Bayswater, Victoria 3153

Telephone (03) 9721 1500
Facsimile: (03) 9720 4144

PACCAR



PACCAR FINANCIAL