

DEFINING TOMORROW

T403





## ● T403

The all new Kenworth T403 combines renowned productivity, comfort and performance in a value package that will deliver the goods in style, day in, day out. Developed as a purpose built aerodynamic solution for intrastate and interstate distribution in single trailer, some vocational 19m B-Double and rigid applications, the T403 utilises a set back front axle and optimal bumper to back of cab dimension.



## ● ADR 80/03 - THE NEW AUSTRALIAN EMISSIONS STANDARD

For the T403 the emission solution employed to meet ADR 80/03 in the 2011 model range powered by Cummins ISX is cooled Exhaust Gas Recirculation (EGR).

Kenworth is introducing a Cummins Particulate Filter as part of the engine package. The Cummins Particulate Filter, which replaces the existing vehicle muffler, reduces particulate emissions by 90% from ADR80/02 levels and is designed to last the life of the engine.

Kenworth's application engineering process has delivered an optimised solution that integrates EGR seamlessly across the high horsepower engine options. So as well as being highly efficient and low maintenance the EGR emission solution has little or no impact on payload and efficiency. Kenworth customers get the emission compliance they need with the proven performance and reliability of engines they know and trust – all with the back up of our renowned local design and manufacturing capability and Australia wide support network.

## ● EBSS - ELECTRONIC BRAKE SAFETY SYSTEM

At Kenworth, safety has always been a paramount consideration, and we continue to invest heavily in developing a safer working environment for road transport operators and other road users. All 2011 new model Kenworth's will be available with the latest Kenworth EBSS Safety Package. EBSS incorporates a variety of safety features including ABS, Drag Torque Control, Traction Control and ESP.

Kenworth EBSS has been designed to provide a class leading and reliable system for Australasia's unique road conditions and applications, and deliver better peace of mind for all road users. To learn more about these safety systems visit [www.kenworth.com.au](http://www.kenworth.com.au)



## NEW DOORS



## NEW AERO STYLING



## NEW HOOD LIFT ASSIST



T403 DAY CAB

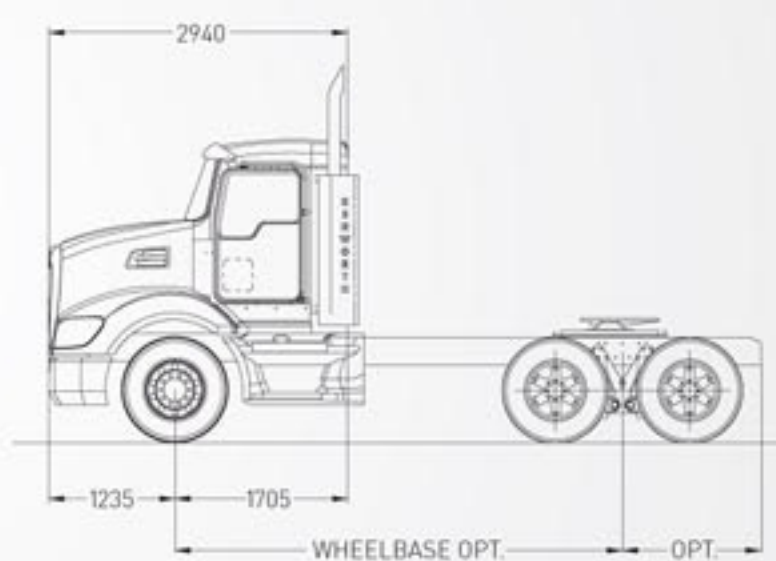

T403 28" IT

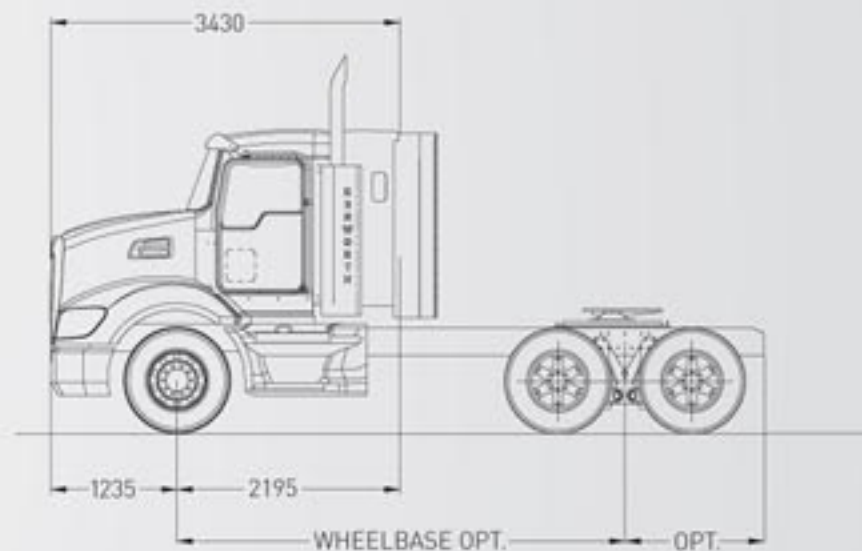

T403 36" RECESSED BACK SLEEPER

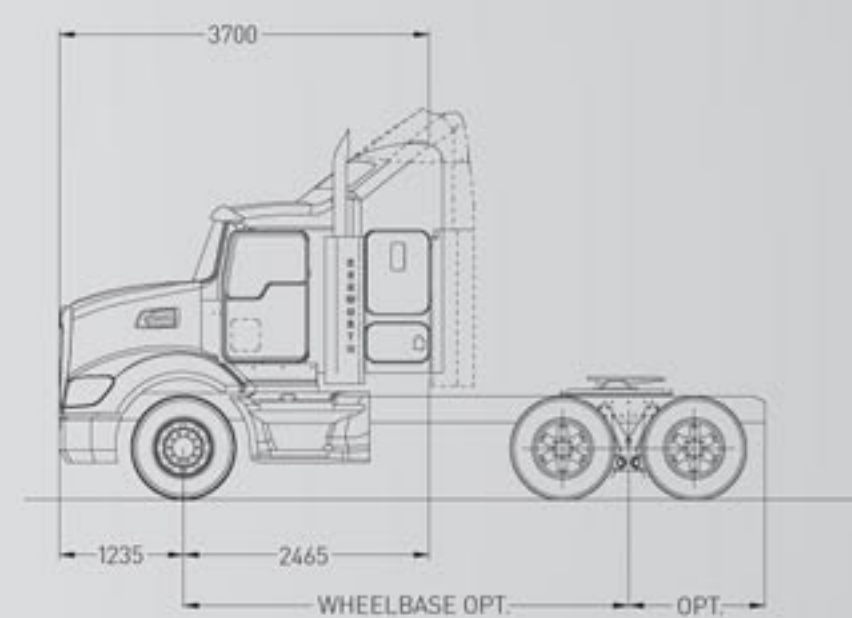

## MAIN SPECIFICATIONS AND OPTIONS

### CONFIGURATION

- 6X4 **standard**

### KITS

- FUEL HAUL & GAS HAUL **optional**

### ENGINE

- ISX EGR 450HP @ 1650 LBFT TORQUE **standard**

### EXHAUST

- DPF MOUNTED UNDER CAB RIGHT HAND FORWARD **standard**
- DPF MOUNTED UNDER CHASSIS **optional**

### AIR CLEANER

- DONALDSON 2501 AIR CLEANER MOUNTED UNDER HOOD **standard**

### TRANSMISSION

- EATON RTLO16918B **standard**
- EATON RTLO18918B **optional**
- Up to EATON RTLO18913A **optional**
- Up to EATON RTLO18918A - AS3 **optional**
- ULTRASHIFT PLUS OPTION
  - FO-16E310C-LAS (10 SPEED) **optional**
  - FO-16E318B-MXP (18 SPEED) **optional**
  - FO-18E318B-LAS (18 SPEED) **optional**

### FRONT AXLE

- DANA E-1462I **standard**
- MERITOR FG941 **optional**

### REAR AXLE

- DANA DSH40P **standard**
- DANA D46-170 **optional**
- MERITOR RT40-145 **optional**
- MERITOR RT46-160 **optional**

### REAR SUSPENSION

- KENWORTH AIRGLIDE 400 **standard**
- KENWORTH AIRGLIDE 460 **optional**

### BRAKES

- DRUM **standard**
- DISC **optional**

### WHEELS

- 6 SPOKE **standard**
- ALCOA 10 STUD **optional**

### SLEEPER

- 28" IT **optional**
- 36" AERO RECESSED BACK **optional**
- 36" AERO FLAT BACK **optional**

### FUEL TANKS

- 400L 625MM DIA FUEL TANK LEFT HAND FORWARD **standard**
- RANGE OF PACKAGES AVAILABLE **optional**

### PAINT

- SINGLE COLOUR TO CAB **standard**
- UP TO 3 COLOURS 2 BREAKS **optional**

### GCM

- 70 TONNE LIMIT



# THE BEST DEALER NETWORK

Kenworth has built an extensive truck dealer network across Australia that is renowned for its professionalism and excellence in the heavy duty truck industry. The Kenworth dealer network also includes highly qualified dealers in New Zealand and Papua New Guinea.



For more information contact your local Kenworth Dealer or go to [www.kenworth.com.au](http://www.kenworth.com.au)

**IMPORTANT:** The vehicles shown in this brochure are for illustrative purposes only and may include some non-standard optional equipment. All weights and measurements should be regarded as approximate only. For full details contact your Kenworth Dealer. In the interests of product improvement, Kenworth reserves the right to change these specifications without prior notice.

PACCAR Australia Pty Ltd,  
64 Canterbury Road, Bayswater, Victoria 3153

Telephone (03) 9721 1500  
Facsimile: (03) 9720 4144

## PACCAR



## PACCAR FINANCIAL