

DEFINING TOMORROW

T359A

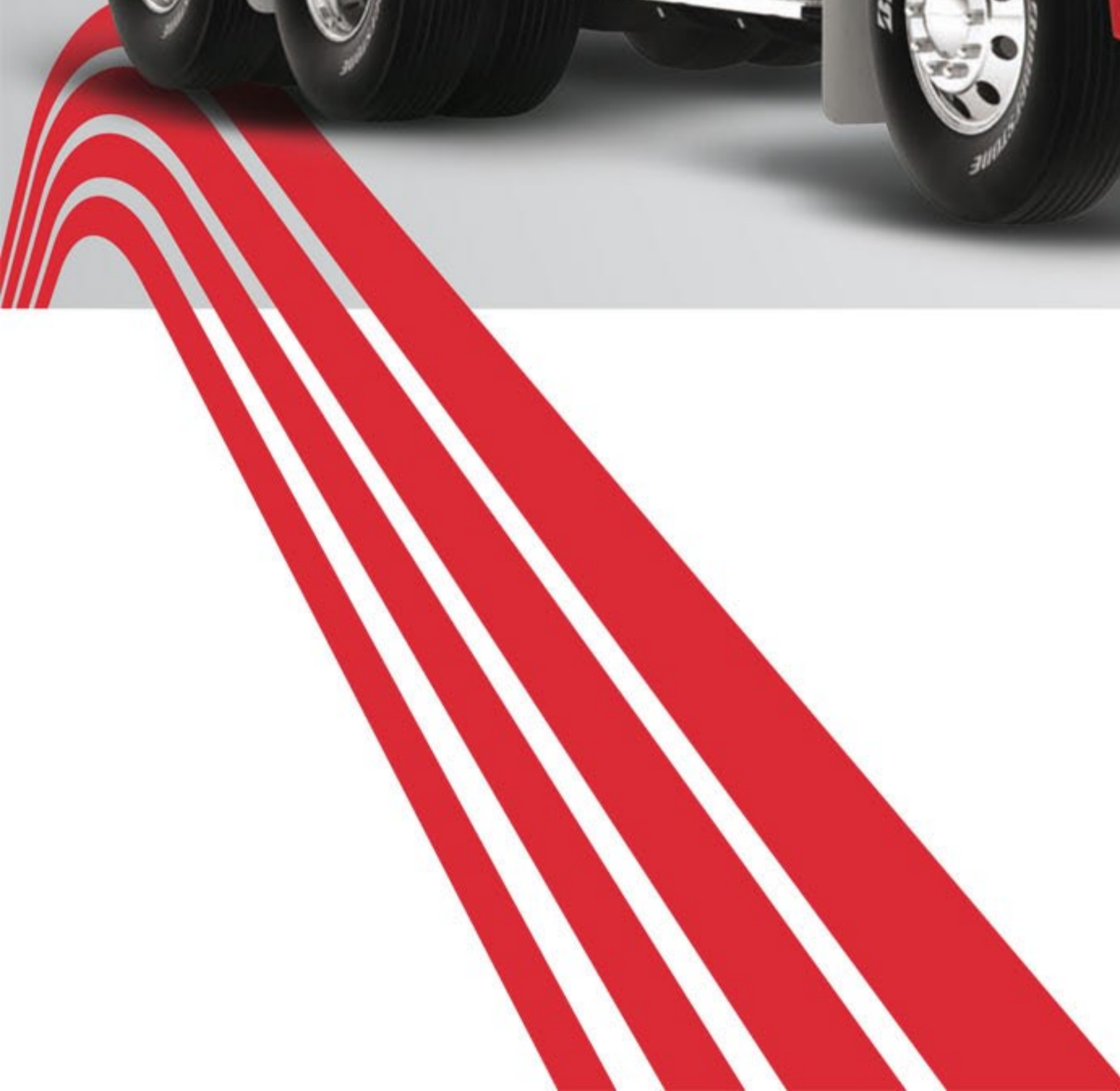

● T359A

With its tight turning circle and short bumper to back of cab measurement the T359A has a level of manoeuvrability and visibility rare in a bonneted truck. Where access is difficult and moving in and out of tight spaces is the norm, the T359A excels. Available in 6x4, 8x4 and 10x4 configurations to suit agitator application.



● ADR 80/03 - THE NEW AUSTRALIAN EMISSIONS STANDARD

There are two emission solutions employed to meet ADR80/03- Selective Catalytic Reduction (SCR) for the smaller engines, and Exhaust Gas Recirculation (EGR) with Diesel Particulate Filter (DPF) for the larger Cummins Engines.

Kenworth's application engineering process has delivered optimised solutions and integrates both EGR and SCR as required, seamlessly across the engine range. So as well as being highly efficient and low maintenance, both cooled EGR with DPF and SCR have little or no impact on payload and efficiency. Kenworth customers get the emission compliance they need with the proven performance and reliability of engines they know and trust – all with the back up of our renowned local design and manufacturing capability and Australia wide support network.

For the T359 with the Cummins ISLe5 engine, SCR is utilised to meet the new standard. The SCR process purifies the NOx from diesel combustion engines by introducing an additive, a urea solution, after the combustion process. The urea solution then converts the exhaust emissions to water and Nitrogen, meeting the 2011 regulations.

● EBSS - ELECTRONIC BRAKE SAFETY SYSTEM

At Kenworth, safety has always been a paramount consideration, and we continue to invest heavily in developing a safer working environment for road transport operators and other road users. All 2011 new model Kenworth's are available with the latest Kenworth EBSS Safety Package. EBSS incorporates a variety of safety features including ABS, Drag Torque Control, Traction Control and ESP.

Kenworth EBSS has been designed to provide a class leading and reliable system for Australasia's unique road conditions and applications, and deliver better peace of mind for all road users. To learn more about these safety systems visit www.kenworth.com.au

NEW FEATURES

The new T359 Kenworth features a wide range of important enhancements- from the significant driver environment improvements to the additional safety features. New doors have been introduced with electric windows as standard, wider more comfortable arm rests, new heavy duty steel key and improved Heater, Ventilation and Air Conditioner Units to keep you warmer in winter and cooler in summer. The T359 available with Front Underrun Protection System (FUPS) bumper including provision for optional driving lights and new bulkhead electrical connections, reducing dust, heat and noise in the cab to improve the driving environment.

NEW DOORS



T359A DAY CAB 6X4

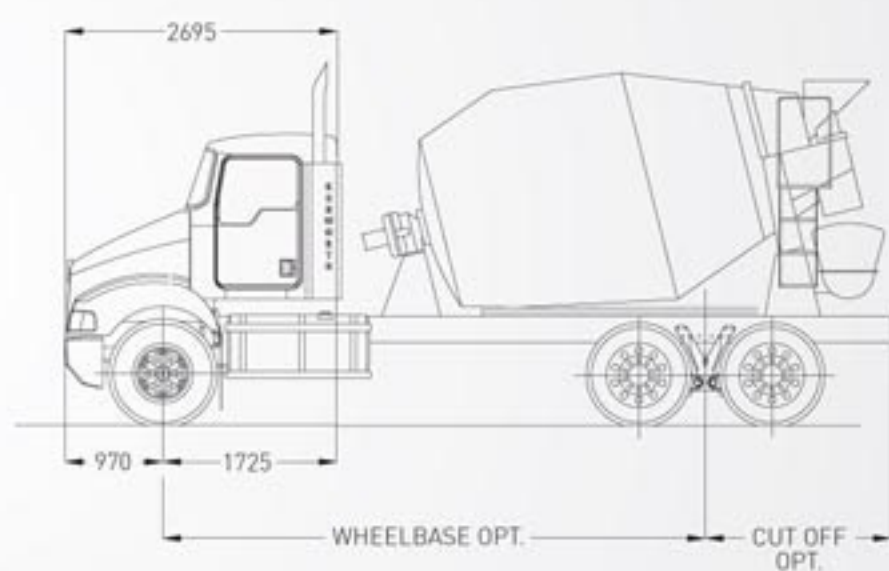

T359A DAY CAB 8X4

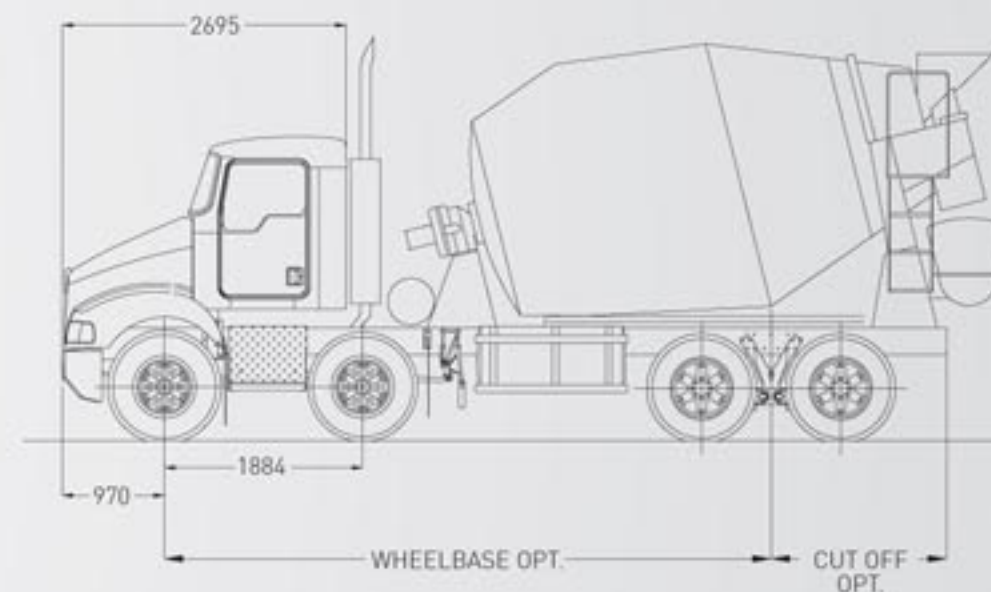

T359A DAY CAB 10X6

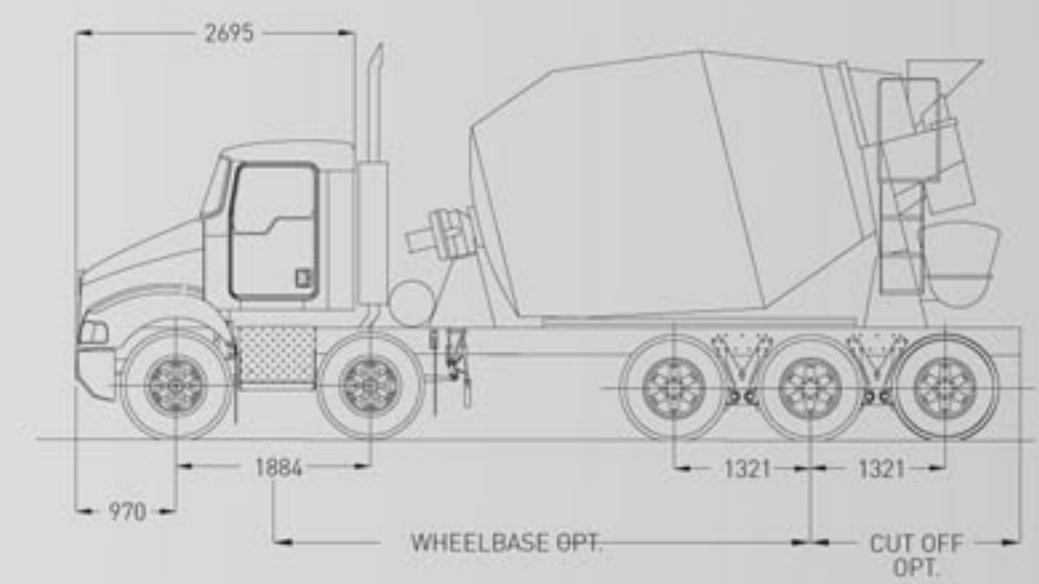

MAIN SPECIFICATIONS AND OPTIONS

CONFIGURATION

- 6X4 **standard**
- 8X4 **optional**
- 10X4 **optional**

ENGINE

- ISLe5 280HP @ 778 LBFT TORQUE - SCR **standard**
- ISLe5 320HP @ 996 LBFT TORQUE - SCR **optional**
- ISLe5 340HP @ 1106 LBFT TORQUE - SCR **optional**
- ISLe5 360HP @ 1180 LBFT TORQUE - SCR **optional**
- ISLe5 380HP @ 1254 LBFT TORQUE - SCR **optional**

EXHAUST

- EGP MOUNTED ON POST LHS BEHIND CAB **standard**

AIR CLEANER

- DONALDSON PLASTIC AIR CLEANER MOUNTED UNDER HOOD **standard**

TRANSMISSION

- ALLISON MD3500P **standard**
- EATON RTO11909A-ALL **optional**
- ALLISON MD3200P **optional**

FRONT AXLE

- DANA E-1462I **standard**
- DANA E-1332I TWIN STEER [8X4 & 10X4 ONLY] **optional**
- MERITOR FG941 **optional**

REAR AXLE

- DANA DSH40P **standard**
- DANA TANDEM W/ LAZY AXLE **optional**
- MERITOR RT40-145 **optional**

REAR SUSPENSION

- KENWORTH AIRGLIDE 400 **standard**
- KENWORTH AIRGLIDE 600 [10X4 ONLY] **optional**
- HENDRICKSEN HN402 **optional**

BRAKES

- DRUM **standard**
- DISC **optional**

WHEELS

- ALCOA 10 STUD **standard**
- STEEL **optional**

FUEL TANKS

- 260L 625MM DIA RIGHT HAND FORWARD **standard**
- 70L 'ADBLUE' UREA TANK RIGHT HAND REAR **standard**
- 180L 625MM DIA LEFT HAND REAR (TWIN STEER) **optional**
- 260L 625MM DIA LEFT HAND REAR (TWIN STEER) **optional**

PAINT

- SINGLE COLOUR TO CAB **standard**

GCM

- 23.5 TONNE LIMIT - 6X4
- 28.5 TONNE LIMIT - 8X4
- 30 TONNE LIMIT - 10X4

THE BEST DEALER NETWORK

Kenworth has built an extensive truck dealer network across Australia that is renowned for its professionalism and excellence in the heavy duty truck industry. The Kenworth dealer network also includes highly qualified dealers in New Zealand and Papua New Guinea.



For more information contact your local Kenworth Dealer or go to www.kenworth.com.au

IMPORTANT: The vehicles shown in this brochure are for illustrative purposes only and may include some non-standard optional equipment. All weights and measurements should be regarded as approximate only. For full details contact your Kenworth Dealer. In the interests of product improvement, Kenworth reserves the right to change these specifications without prior notice.

PACCAR Australia Pty Ltd,
64 Canterbury Road, Bayswater, Victoria 3153

Telephone (03) 9721 1500

Facsimile: (03) 9720 4144

PACCAR



PACCAR FINANCIAL