

T350

“Specifically designed and application engineered in Australia for short haul and urban operations hauling up to 46 tonnes, the T350 is the latest addition to the range of heavy duty trucks from market leader Kenworth.”*



**Subject to application approval.*



Versatility

Where difficult access is the norm, and traffic and time pressures are never far away, the T350 excels as it moves in and out of tight spaces all day, every day. The tight turning circle and short bumper-to-back-of-cab measurement makes the T350 a very versatile and agile performer.

Developed for single trailer, metro distribution and short haul applications, the T350 offers the same reliability and durability for which Kenworths are renowned.

Driving around town the T350 will give you a level of visibility and manoeuvrability rare in a bonneted truck.



“Designed to take tough loads in tight spaces.”



At Home in the City

The ease of access and safety around town of the bonneted T350 puts it in a class of its own.

Drivers in this heavy traffic environment are required to get into and out of the cab so often, cab access must be exceptionally simple and safe.

The aluminium and fibreglass cab, which is designed to be big on strength and low on unnecessary weight, is built around a corrosion-resistant frame and offers the professional driver all-round comfort with easy access via two tank-mounted aluminium steps.

Interior trim is mounted over 3D polyester acoustic insulation that minimises noise and heat, adding to driver comfort.

Exceptional Visibility

The curved one-piece windscreen coupled with the steeply sloped hood provides excellent forward vision. DAYLITE doors, standard on all T350 models, provide excellent sideways vision, which is of particular importance in tight manoeuvring situations.

Large heated mirrors and spotter mirrors assist the driver to clearly see what is happening behind the truck.



Great visibility.



DAYLITE doors standard.



Safe and simple cab access for driver and passenger.



All the creature comforts, and a full range of trim colours.



Features for Functionality

Set your own specifications by choosing from the many options and features the T350 has to offer.

Available in single or tandem drive, the T350 comes with the acclaimed Airglide alloy pedestal rear suspension and a choice of Dana or Meritor rear axles.

The T350 offers a range of Fuller transmissions, from 10 to 18 speed, including Autoshift and Ultrashift.

There are a choice of fuel efficient Cummins and Caterpillar engines available with up to 410hp and 1450lb/t of torque.

Your workshop will love the ease of servicing the T350 and the design simplicity and lower costs of a Kenworth chassis and driveline.

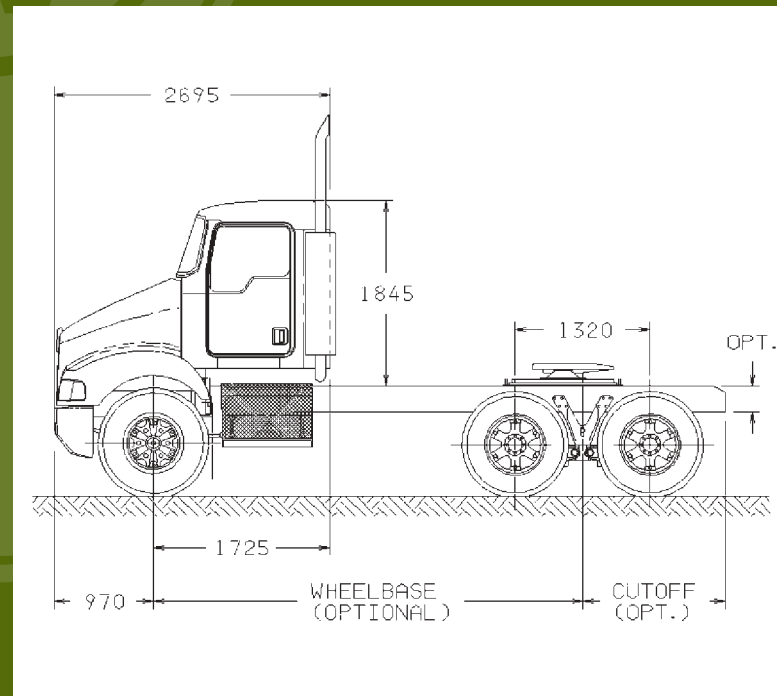

Service access is a breeze for the only bonneted truck in its class.

