



T350 Agitator

The most professional dealer network

Every Kenworth truck is supported in the field by a comprehensive network of highly qualified dealers throughout Australia, New Zealand and Papua New Guinea. Each has a history of excellence in the heavy duty truck industry.

Kenworth's on-line parts system provides owners with unmatched service. And each dealership has a complete Bill of Material for every Kenworth truck built, so when you want a part for your truck, there's no guesswork.

Made in Australia

Kenworth trucks are designed and manufactured in Australia to perform in some of the toughest and most demanding applications found anywhere in the world. They are application-engineered to exacting standards, using the best technology and componentry.

On a whole-of-life cost basis, there are few trucks that can approach Kenworth in helping to produce a better bottom line for your business.

An enviable record

From its beginning in Bayswater, Victoria in 1971, Kenworth's Australian operations have developed into a world class design, development, manufacturing and testing facility incorporating advanced training services and its sophisticated PACCAR Parts warehouse and distribution centre.

With more than 30,000 trucks delivered, Kenworth Australia provides products and services to the transport sector that are the envy of the industry worldwide.



IMPORTANT

The vehicles shown in this brochure are for illustrative purposes only and may include some non-standard optioned equipment. All weights and measurements should be regarded as approximate only. For full details contact your Kenworth Dealer. In the interests of product improvement, Kenworth reserves the right to change these specifications without prior notice.



ABN 43 004 669 667
www.kenworth.com.au

AUSTRALIAN MADE. WORLD'S BEST.



T350 Agitator



The perfect mix for a specialised application



Service access is a breeze.

T350 Agitator

The concrete distribution industry demands a unique breed of vehicle. It's got to be able to handle maximum payloads in tough conditions, while working in heavy traffic and on congested construction sites.

A derivative of the T350, the T350 Agitator is tailor made for the agitator market, available in both 6x4 and 8x4 variants. With its short BBC the T350 Agitator has all the positive attributes of a Cab Over Engine design – manoeuvrability, visibility and minimal overall length, together with the benefits of a Conventional – driver safety, OH&S advantages including ease of egress/ingress, serviceability, and a walk through cab design.

Above all the T350 Agitator spec is based on the same design and quality foundation that comes with all heavy duty Kenworth models – best in class performance, robust 270mm chassis rails, light tare weight, fuel economy, reliability, driver satisfaction, lower cost of ownership and the acclaimed Kenworth AIRGLIDE suspension system with superior roll stability.



All the creature comforts and a full range of trim colours.

Features

- Tailor made for the agitator market - designed with industry input
- Optimal axle locations to maximise payload
- Extra payload capability under mass management where applicable
- Light tare weight and up to 6.5m³ barrel capacity (6x4) and 7.5m³ (8x4) to maximise productivity (subject to barrel specifications)
- Short BBC (2695mm) for manoeuvrability, visibility and minimal overall length
- Inherent safety benefits of a conventional design
- OH&S friendly through ease of egress/ingress, serviceability and a walk through cab design
- Best in class performance
- Robust 270mm chassis rails
- Kenworth AIRGLIDE suspension system with:
 - dual load level sensors
 - 8 x airbags
 - 1 inch porting
- Legendary Kenworth reliability, durability and driver satisfaction
- Lower whole of life cost of ownership

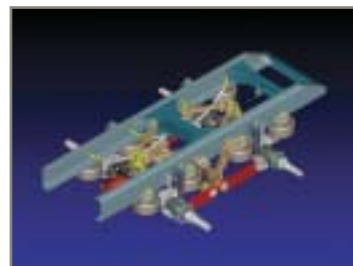

Kenworth AIRGLIDE 400 airbag suspension.

T350 Agitator 6x4	Standard	Optional
Engine	Cummins ISC 265	Cummins ISC 285 and 315 Repto PTO, Extarder
Transmission	Allison MD3560P Chelsea PTO	RTLO 12913A MD 3066P RTO11909ALL
Rear Axle	DSH40 6.17 Ratio	DS/RDH40 DD/RDH40 Ratios to Suit
Rear Suspension	AIRGLIDE 400	HN402
Base Features	Lightweight spec plus 150L fuel tank, rev alarm, hour meter, A/C, 285 PCD alloys, radio/CD, in-cab control, peeper window and mirror, park brake alarm, 'Ready for barrel'	Revolving light Cabmate air suspension Adjustable steering column 260L Fuel Tank.
Tare Weight	6220 kgs*	

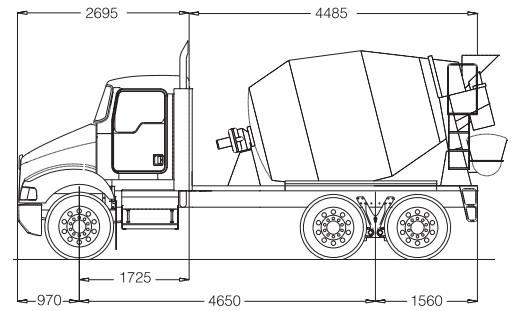

*Estimated weight; includes full fuel, cab and chassis only, ±2%

T350 Agitator 8x4	Standard	Optional
Engine	Cummins ISC 285	Cummins ISC 315 Repto PTO, Extarder
Transmission	Allison MD3560P Chelsea PTO	RTLO 12913A MD 3066P RTO11909ALL
Rear Axle	DSH40 6.17 Ratio	DS/RDH40 DD/RDH40 Ratios to suit
Rear Suspension	AIRGLIDE 400	HN402
Base Features	Lightweight spec plus, 180L fuel tank, rev alarm, hour meter, A/C, 285 PCD alloys, radio/CD, in-cab control, peeper window and mirror, park brake alarm, 'Ready for barrel'	Revolving light Cabmate air suspension 260L Fuel Tank Adjustable steering column
Tare Weight	7550 kgs*	

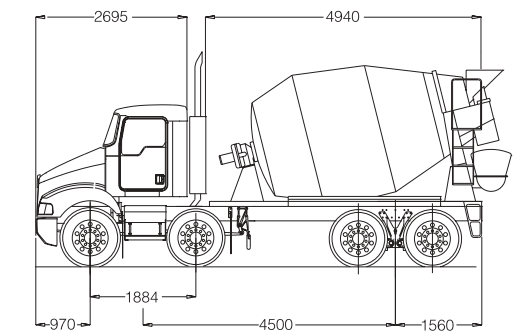

*Estimated weight; includes full fuel, cab and chassis only, ±2%



Vehicles shown with optional accessories. The Kenworth T350 Agitator is supplied cab chassis only. Barrel and accessories to be sourced from third party suppliers.

