



KENWORTH
THE WORLD'S BEST

T170

Class 5



KENWORTH HAS TAKEN EVERYTHING IT KNOWS ABOUT BUILDING RUGGED, RELIABLE, PRODUCTIVE, PROFIT-MAKING TRUCKS AND BUILT IT INTO THIS, THE T170

The Kenworth T170 is a custom-built Class 5 truck perfected for the toughest jobs. This highly versatile vehicle blends excellent visibility with maneuverability, a driver-pleasing interior and a chassis so durable it will likely outlive the body you put on it. A straight truck in a 4 x 2 configuration with a gross vehicle weight rating up to 19,500 lbs, the T170 comes equipped with a fuel-efficient PACCAR PX-6 engine, hydraulic brakes, manual or automatic transmissions and a selection of components from proven North American manufacturers.

Engineered for reliable, long-lived performance, the T170 features Kenworth's legendary conventional cab – a strong and quiet environment unmatched



KENWORTH.
The World's Best.

in the industry for longevity and comfort. A large, post-free windshield, fixed rear window, right hand door peeper window and optional corner windows all combine to enhance visibility in tight spots.

The quiet, fully-trimmed interior is doghouse-free to increase floor space and operating convenience. The instrument panel is exactly what you would expect in a real truck – with large, easy-to-read gauges and quick access to driver controls.

Options include a telescoping and tilting steering wheel, a workstation with two 12-volt power ports and an electronic shift module.



An advanced halogen forward lighting system provides up to 30% more down-road coverage than conventional sealed beam designs.



The hood tilts a full 90 degrees for clear access to the engine compartment from both sides. All fluid level checks and fills can be handled quickly, standing in one place.



The four-piece hood and fenders are molded from Metton, a high-tech light weight composite material for added durability and repairability.



The fully-trimmed Pinnacle interior shown with high-back driver seat and toolbox riders seat. Optional burl wood dash inserts and two-person bench seat with under seat storage are available to customize your interior.



MEDIUM DUTY SUPPORT AND SERVICES

The reliability and moneymaking potential of your business relies on the dependability of your support system – another great reason to invest in a Kenworth.

The minute you take delivery of your Kenworth, you gain 24/7 access to one of the most extensive and reliable parts and service organizations in the trucking industry. People who know your truck inside out and can show you how to lower operating expenses, maximize uptime, optimize truck performance and profit from your investment. Comprehensive preventive maintenance programs, expedited servicing, complimentary roadside assistance and cost management service cards are among the valuable programs available through Kenworth PremierCare®.



Start with a lender who understands your business. PACCAR Financial has served owner-operators and fleets for over 40 years, matching individual requirements with customized financing packages at attractive and competitive rates. Financing and insuring your new truck has never been this easy. www.paccarfinancial.com

Perhaps you'd prefer to focus your attention and resources on your core business, save interest expense and improve cash flow. PacLease offers a number of truck rental and leasing programs that can be tailored to fit your operating requirements precisely. www.paclease.com



T170 CLASS 5 SPECIFICATIONS

Power / Drivetrain

- PACCAR PX-6 Engine, 6.7 Liter, 200-300 HP, 520 – 660 lb-ft of Torque
- CARB Emission Reduction Feature Available

Starting & Charging

- Electrical System with Centralized Power Distribution Incorporating Plug-In Style Relays & Circuit Protection for Serviceability
- 12 Volt Lighting System with Circuit Protection
- Circuits Numbered & Color Coded
- Key Switch Start & Shutdown
- 160 Amp Alternator
- PACCAR 12 Volt Starter
- Two PACCAR Dual Purpose Batteries
- Horizontal Muffler/DPF and Tailpipe

Transmission Options

- Eaton Fuller FS5406A Synchronized 6-Speed
- Clutch - Eaton Fuller
- Eaton Fuller FS6406A 6-Speed
- Eaton Fuller FS06406A 6-Speed Overdrive
- Allison 1000HS 5-Speed Automatic
- Allison 1000RDS 5-Speed with PTO Drive Gear

• *Optional Items in Italics*

Frame / Axle / Suspension / Brakes

- Frame - 9 7/8" Steel - 120,000 psi - Heat Treated
- Front Axles - Dana Spicer, 8,000 lb.
- Front Springs - Taperleaf w/Shocks, 8,000 lb.
- Rear Axle - Dana Spicer, 11,500 lb.
- Rear Suspension - Reyco, 13,500 lb.
- Brakes - Hydraulic
- ABS System - Meritor

Wheels / Tires

- Wheels - Steel 19.5"
- *Optional Polished Aluminum 19.5"*
- Tires - Bridgestone 245/70R19.5"

Fuel Tanks

- Steel - Rectangular 35 Gallon
- *Optional Dual 30 Gallon*

Battery Boxes / Bumpers

- Steel Battery Box and ABS Cover
- Bumpers - Steel Aero-Style Painted Gray

Cab / Hood / Interior

- Cab - Aluminum and Composite
- Hood - 4-Piece Metton - Sloped Aerodynamic Hood
- Standard Cloth Headliner and Vinyl Cab Back Panel
- Power Door Locks
- Passenger-side Electric Window
- Kenworth Air Cushion High Back Driver Seat
- Kenworth Intermediate and High Back, Air and Toolbox Rider Seats
- 2-Person Bench Seat
- Rear Cab Corner Windows
- Full Burl Wood Dash Panels
- Workstation Between Seats

Special Equipment & Options

- Aerodynamic Heated Mirrors
- Back-up Alarm
- Daytime Running Lights
- Multi-function Engine Connector for Body Builder Interface
- Bodybuilder Harness
- Adjustable Telescoping Tilt Steering Column
- Remote Keyless Entry

Note: Photography and illustrations in this brochure may depict optional equipment. All equipment and specifications shown in this brochure are subject to change without notice. Please consult with your Kenworth dealer at the time of ordering for actual standard and optional equipment.

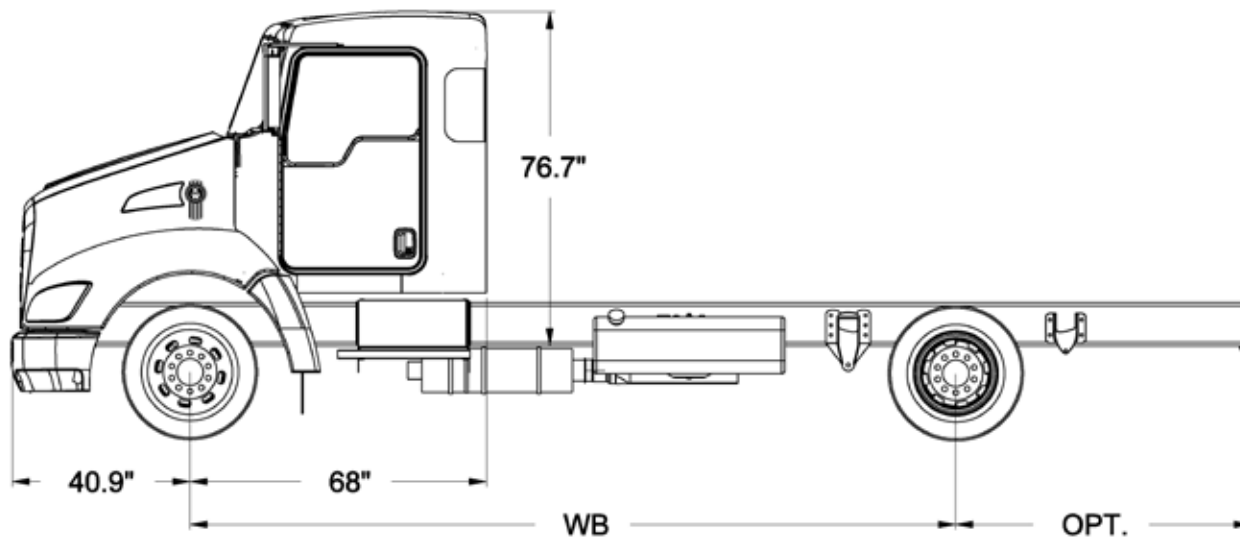
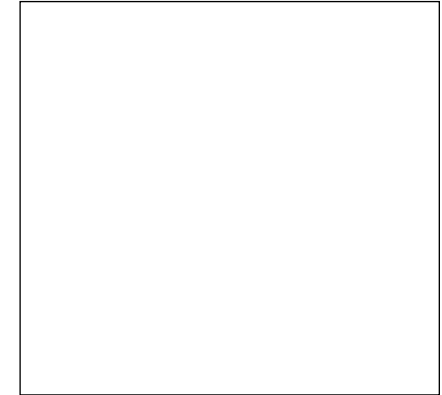

Available Wheelbases: 152", 176", 188", 206", 218", 236", and 245"



A DIVISION OF PACCAR

KENWORTH TRUCK COMPANY

P.O. Box 1000

Kirkland, Washington 98083-1000

(425) 828-5000

CANADIAN KENWORTH COMPANY

6711 Mississauga Road N.

Mississauga, Ontario L5N 4J8

(905) 858-7000