



KENWORTH
THE WORLD'S BEST

K260



KENWORTH K260 MEDIUM DUTY CABOVER SPECIFICATIONS

GVWR – 26,000 Class 6

When your business requires the most dependable pick up and delivery vehicle, take a look at Kenworth.

From the front bumper to the back of cab, only 63.2 inches, plenty of room for a large van body and still get the maneuverability offered by the 55 degree wheel cut.

The Kenworth K260 is available with either an air suspension or mechanical in wheelbases of 189 and 210 inches. The air suspension can be lowered or lifted from inside the cab or by use of the remote control module from outside of the cab. A time saving for drivers with one less need to get into the cab during deliveries.

The cab easily accommodates three people in its spacious 92.5 inch width. The driver air-suspended seat and the two-person bench seat is separated by the transmission shift lever and parking brake, within easy reach. The driver has a master display information module on the dash which provides information on fuel consumption, service inspections, oil level, trip information, time, fault codes and even an alarm clock.

For easy backing into docks at the correct height in your K260, two pre-set heights are available.

Cab

Hydraulic 55 degree Tilting Steel Cab.
 78.3 inch top of frame rail to top of cab
 63.2 inch BBC
 52.2 inch bumper to center of front axle
 92.5 inch cab width
 Driver Seat – Air Suspension
 Passenger Seat – 2-person bench
 Heater and Air Conditioning
 Cruise Control
 Power Windows
 Doors open 90 degrees
 Cab Suspension – Maintenance-Free
 Dash Displays – English or Spanish
 Kenworth AM/FM/CD Radio – 12 volt
 Heated Mirrors

Paint

Cab – Brilliant White DuPont H3279
 Frame – Black DuPont N0001

Axles (Rated for 26,000 lbs)

Front 10,000 lbs
 Rear 21,000 lbs, 4.56 Ratio

Suspensions

Front Suspension – Parabolic Spring
 Rear Suspension - Mechanical or Air

Electrical System

Exterior lighting 12 volt
 One 12-volt power port in cab
 Body connections 12 volt
 Balance 24 volt

Frame

31-inch frame spacing
 Steel Bumper

Section properties per rail:

Frame	Section modulus	RBM
	9.80 cu in	653,454 lb/in

Frame Height With Air Suspension

Ground to top of frame laden	35.39 inches
Ground to top of frame unladen	36.65 inches
Max raised position above ride height	- 5.24 inches
Max lowered position below ride height	- 3.31 inches

Wheelbases

189" (4.8M)
 210" (5.35M)

PACCAR Engine

PACCAR 6 cylinder, 5.9 L, 2007 compliant
 220HP@2200 600@1200-1700

Alternator – 80 amp

Transmission – ZF Overdrive 6-speed

Fuel Tank – 52.8 gallon rectangular

Exhaust – Horizontal, with high level air intake

Wheels – 19.5 inch steel painted silver

Tires – Bridgestone 285/70R19.5

Brakes – Air Disc Front and Rear

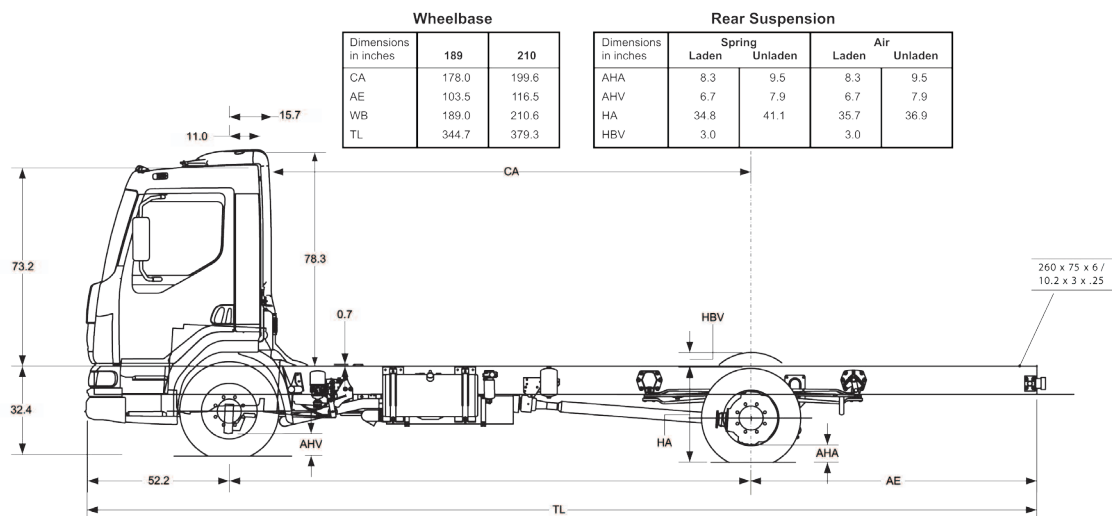

Note: Photography and illustrations in this brochure may depict optional equipment. All equipment and specifications shown in this brochure are subject to change without notice. Please consult with your Kenworth dealer at the time of ordering for actual standard and optional equipment.

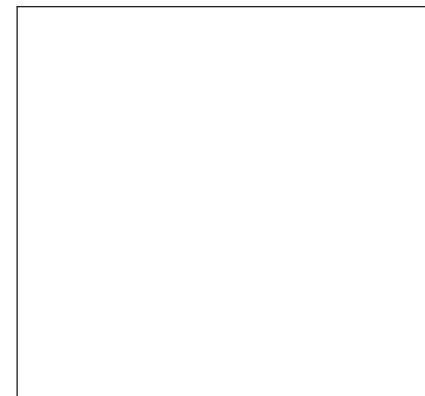

A DIVISION OF PACCAR

KENWORTH TRUCK COMPANY

P.O. Box 1000

Kirkland, Washington 98083-1000

(425) 828-5000

CANADIAN KENWORTH COMPANY

6711 Mississauga Road N.

Mississauga, Ontario L5N 4J8

(905) 858-7000