

Kenworth

LH-D 230/270 SERIES

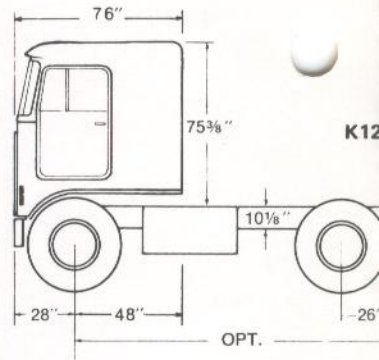

Four models: Two cab styles, 230hp or 270hp engine!



LH-D 230

K125 CR — 230
W 925 S2R — 230

STANDARD SPECIFICATIONS

Three axle truck (6 x 4) single reduction rear axle.
160" wheelbase. Bumper setting 28"
50,000 lb. G.V.M. 100,000 G.C.M.

SPECIFICATIONS INCLUDE

ENGINE: Cummins Diesel NTC-230, 855 cu.in.,
230 hp at 2100 rpm. By-pass oil filter, water filter and
fuel filter, 14" dry type air cleaner, 22" diameter fan,
fuel filter, single exhaust.

RADIATOR: 1200 T core, cadmium plated grille and
full radiator shroud.

ELECTRICAL EQUIPMENT: Delcotron 65-amp
alternator, 12-volt lighting, 24-volt starting. Four 6-volt,
19 plate batteries.

TRANSMISSION: Fuller Roadranger RT915, 15 speed
with 14" two-plate clutch. SAE # 1 bellhousing, cast
iron case.

PROPELLER SHAFTS: Spicer 1710 Series needle
bearing, balanced tubing.

FRONT AXLE: Rockwell FF-931-TW 12,000 lb.
capacity. Front axle shock absorbers.

REAR AXLE: Eaton DS 380 (4.56:1) on Kenworth
"Spherical" torsion bar suspension with 38,000 lb.
capacity.

SERVICE BRAKES: Rockwell "S" cam air brakes.
13.2 CFM Cummins compressor, quick release valve
and front wheel limiting valve. Flexible air piping.
Brake size front: 15" x 4" — area 246 sq.ins. Brake
size rear: 16½" x 7" — area 868 sq. ins. Air operated
emergency release system on parking brakes.

TYRES: 10.00 x 20, 12-ply, highway tread (ten furn-
ished).

WHEELS: Spoke type; 7.5" x 20" rims (eleven furn-
ished).

FRAME: Heat-treated alloy steel channel. Dimen-
sions: 10 1/8" depth, 3¼" flanges, 5/16" thickness,
free fit all bolted construction.

CAB: Kenworth cab. Steel frame, aluminium bulkhead
doors with continuous weather seals and piano type
hinges. Windscreen laminated, safety glass throughout.
Air ride driver's seat, toolbox rider's seat, dome light,
dual motor air windscreen wipers, windscreen washers,
sunvisors, cigar lighter, ashtrays, Grover air horn, electric
horn, dual exterior mirrors. Console tilt out dash.
Instruments: Speedometer, tachometer, fuel gauge,
ammeter, oil pressure, water temperature and air reservoir
pressure gauges, low air pressure wig-wag, low oil temp-
erature warning lights. Lights: Dual headlights, park
lights, amber turn signals, stop, turn, and tail lamps.

SPECIAL EQUIPMENT: Heater/demister-cab fan, lap/
sash belts on both seats deluxe cab and door trim.

FUEL TANK: 380 litre aluminium.

STEERING GEAR: Sheppard 492 Integral power
steering and 22" diameter adjustable steering wheel.

STANDARD EQUIPMENT: Aluminium bumper with
integral tow hook. Spare rim, wheel wrenches and 12
ton hydraulic jack. Steel battery box.

PAINT: Low bake enamel in any one colour.

Specifications subject to change without notice.