



m300H_{x4}

EL VEHICULO MULTIUSOS QUE FACILITA TU TRABAJO
THE TOOL-CARRIER THAT MAKES YOUR WORK EASIER
MULTITASK-GERÄTETRÄGER, DAS FAHRZEUG FÜR DEN HARTEN EINSATZ
LE VEHICULE MULTISERVICE QUI FACILITE TON TRAVAIL

MULTI
Task



www.ausa.com

AUSA Center, S.L.U. ● Ctra. de Vic, Km 2.8 - P.O.B. 194, 08243 Manresa - BARCELONA (ESPAÑA) Tel.: +34 93 874 73 11 E-mail: ausa@ausa.com

ISO 9001

ISO 14001



(Sede central AUSA-Manresa)

AUSA Madrid ● Pol. Ind. Coslada-Marconi 15-17, 28823 Coslada - MADRID (ESPAÑA) Tel.: +34 91 669 00 06 E-mail: ausa.madrid@ausa.com
AUSA France ● Z. I. Saint Charles-Rue de Zürich, 66000 PERPIGNAN (FRANCE) Tel.: +33 (0) 4 68 54 38 97 E-mail: ausa.france@ausa.com
AUSA ● Unit 16 Hollows Works - Shawclough Road - Rochdale - Lancs OL12 6LN (U.K.) Tel.: +44 (0) 1706 64 96 91 E-mail: ausa.uk@ausa.com
AUSA Repräsentanzbüro Deutschland ● Heinrich-Welken Straße 5, 59069 HAMM - RHYERN (GERMANY) Tel.: +49 2385922245 E-mail: ausa.deutschland@ausa.com
AUSA Northamerica Corp. ● 2655 Le Jeune Road - Suite 808, CORAL GABLES FL 33134 (USA) Toll free: 1 800 820 AUSA E-mail: ausa.corp@ausa.com
BEIJING Rep. office ● Address Room 527, HengXiang Building, Tuanjiehu Nanli, Chaoyang District. - Beijing 100026 CHINA
Tel: 86-10-8597 1983 - Fax: 86-10-8597 1993 - E-mail: ausa.china@ausa.com



M 300 H 2500 Kg

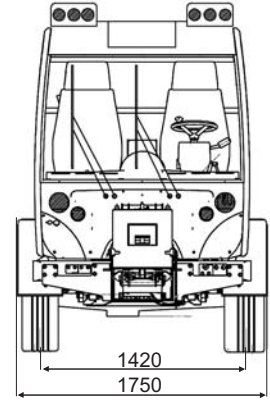
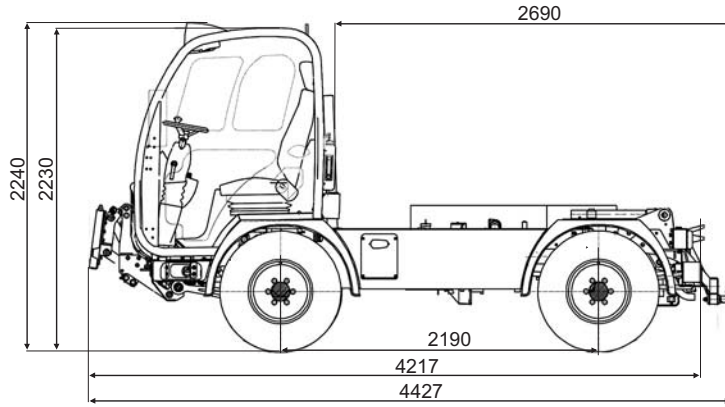

TECHNICAL SPECIFICATIONS

Load capacity (kg)	2500		Gradient negotiable (with full load)	45%
Hopper capacities (l)	Levelled	1500	Brakes	Hydraulic pump with servobrake on front wheels with self-ventilated discs and drum discs on rear wheels. (with parking brake)
	Heaped	2000		
Engine	Make	VOLKSWAGEN	Steering	Hydraulically assisted TRW
	Type	2,01 TDI PD EURO 4		
	Power acc. (Kw - Cv)	74 - 100 (3000 rpm)	Suspension	Front axle with springs and hydraulic shock absorbers. Rear axle with helycoidal leaf springs and hydraulic shock absorbers
	N. of cylinders	4		
	Cooling	Liquid	Attack	Obstruction angle 26° Departure angle 62°
	Fuel	Diesel		
Fuel capacity (l)	70		Weight (Kg)	Unloaded weight 3230 (1900 front axle ; 1330 rear axle) Gross weight 5500 (2250 front axle ; 3750 rear axle)
Transmission	2 hydrostatic gear 2 gear speed-reducer			
	Ground speed (Km/h)	62		Hydraulic delivery
Traction	4x4 continuous with central differential, COMPEN system		Hydraulic power take-off	

STANDARD EQUIPMENT

Closed cabin with heating	Doors with panning visibility	Passenger seat with pneumatic suspension	Heated rear mirrors elect. adjustable
Electronic boost of rpm	Front plate for attachments	Homologated light system elect. adjustable	Rotating beacon

OPTIONAL EQUIPMENT

All-terrain, mixed or wide turf tyres	Towing point (⊙ 50mm)	Air conditioning	-
Spare wheel	Homologated "Rockinger" towing point	Tachometer	-

ACCESSORIES

Sweeper	3m3; 650 liters of water; 13.000 m3/h; maximum sweep width: 2.8 m
Movex platform	working height: 15m; load on basket: 200 Kg (2 persons); rotation: 360°
Bush cutter	Lateral bush cutter; Reach: 3 m
Washing bar	Water tank: 2000 l ; pressure: 150 bar; flow: 17 l ; washing width: 2m

TRANSPORT

Transport box	Standard box. Dimensions of 1.600 x 2.640 x 300 mm (width x length x height) Short standard box. Dimensions of 1.850 x 2200 x 300 mm (width x length x height) Loading capacity of 2.500 Kg
Towing	Dimensions: 1.700 x 2.700 x 400 mm (width x length x height) and loading capacity of 3.500 Kg.
Trilateral	Standard trilateral: Dimensions: 1.700 x 2.600 x 400 mm (width x length x height) Short standard trilateral: 1.850 x 2.200 x 400 mm (width x length x height). Unloading angles at 3 directions up to 46° and loading capacity of 2500 Kg.
Container-holder	Maximum dimensions of the transport loading: 1.220 x 2.400 mm (width x length) and loading capacity of 2.500 Kg. (Distance between arms: 1.360 mm)

PACKS



SNOW PACK

Snowplough blade with a sweeper width of 2 m. and lateral inclination up to 30°.

Regulable salt-spreader with a capacity of 1.2 m3.
Optional: gravitational salt-spreader



SUPPORT PACK

Palfinger crane with a capacity of 280 Kg. at a height of 8.10 metres.

Optional: Unique homologated crane in the market to be used as elevator-people. Basket with remote control. Able to elevate 1 person and tools (120 Kg) at a working height of 10.7 metres.

AUSA reserves the right to make any changes in the specifications without prior notice