



## The Mobility Elite.

MAN Military Trucks HX, SX.





## Logistic challenge.

Traditional thinking about enemy doctrine is replaced by new types of conflicts. Today the international community is faced with threats of a very different kind – on the one hand natural disasters, local and regional conflicts and on the other the danger of international terrorism. Global crisis prevention, conflict management and

peacekeeping organisations are confronted with complex security challenges. Flexibility and mobility are necessary to guarantee a rapid presence at the scene of a crisis. Perfect logistic and tactical support of the forces is crucial to success.

As one of the leading international commercial vehicle manufacturers with great expertise and experience in building military vehicles, MAN makes a major contribution to conflict resolution and crisis management. Beside the militarized vehicles in the TGA, TGM and TGL ranges the HX and SX ranges, specially developed

to meet military requirements, play an outstanding role. Designed in particular for global logistic and tactical off-road operation they combine maximum mobility and reliability with great operating economy and efficiency. Their mission is to keep the peace.

Some of the equipment illustrated or described in this brochure is not a standard feature.



## Off-road. No limits.

They battle through desert sands and along stony tracks, over scree and mud, snow and ice. Climb the most extreme gradients, ford rivers and chase across any terrain. MAN HX and SX all-wheel-drive trucks just keep on moving. Capitulation is not an option whatever the terrain.



With their excellent off-road qualities the all-wheel-driven, single-tyre mobility trucks are a match for practically any surface they come across. The SX in particular takes things in stride: Full speed ahead is the name of the game. It's no coincidence that we also call it the Extreme Mobility Truck System. And hot on the heels of the SX comes the High Mobility Truck System HX. The name says it all.





Could the HX and SX ever get in it up to their neck? Not a chance, since they are ideally equipped even for deep water. Without preparation for instance the SX has a fording depth of 1200 mm in accordance with STANAG 2805. Their service profile includes a large ground clearance, very good angles of approach

and departure and enormous permanent climbing capacity (60 %) together with a ditch crossing ability of up to 1.9 m (depending on the wheel formula), a step climbing ability of 0.6 m (depending on the tyre size) and a maximum side slope of 40 %.

Last but not least they are designed for climatic zones A1 to C1 according to STANAG 2895, and even with the series equipment they can withstand extreme outside temperatures from minus 32 to plus 49 degrees Celsius. The HX and SX prove their mobility in

other respects too: Depending on the selected vehicle within the complete range they can be airlifted by C130, C160 and A400M aircraft and guarantee rail transportability within the common rail tunnel dimensions.

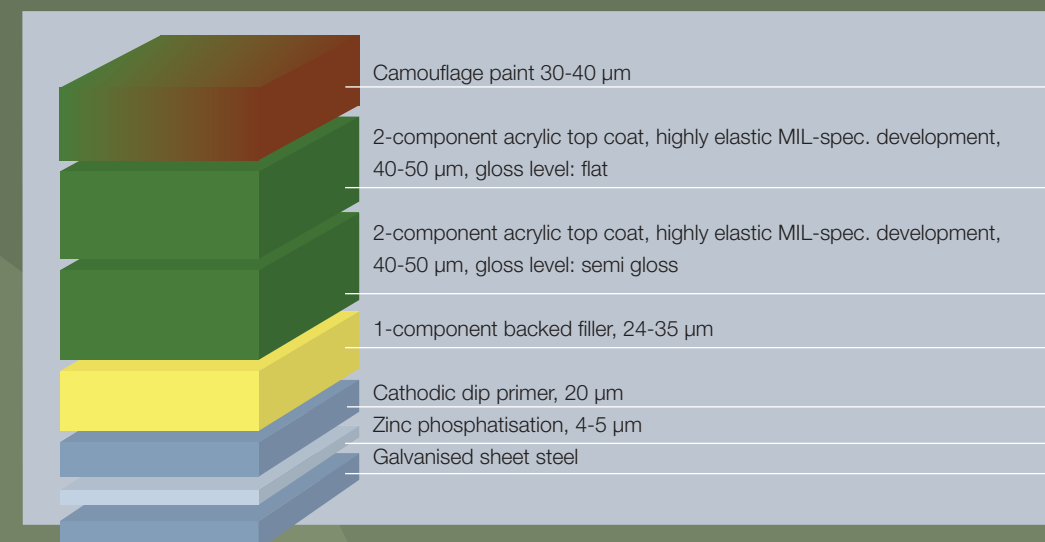
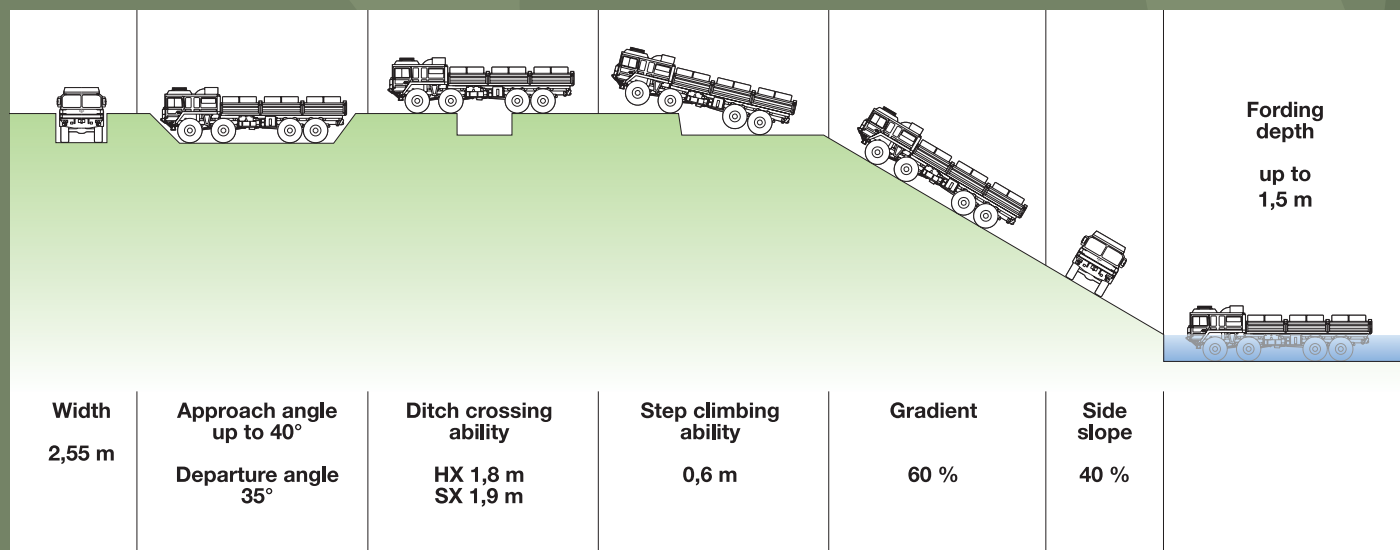

## Military excellence.

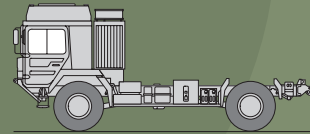

HX 60, Air-transportable

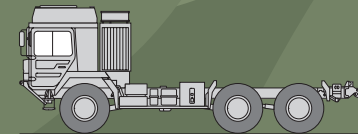

HX 61, Air-transportable

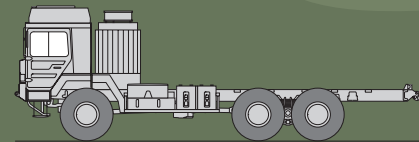

HX 58

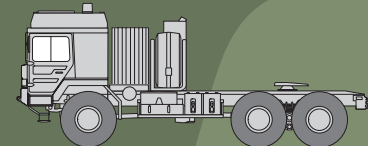

HX 80

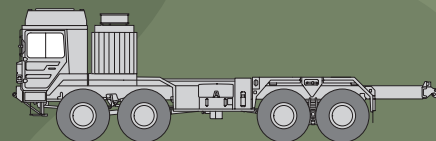

HX 77

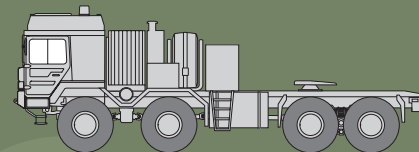

HX 81

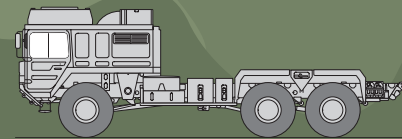

SX 44, Air-transportable

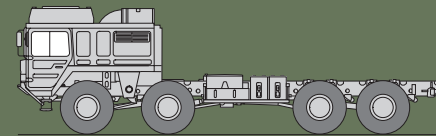

SX 45, Air-transportable

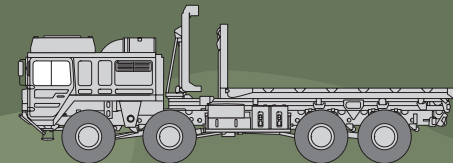

SX 45 MULTI 2

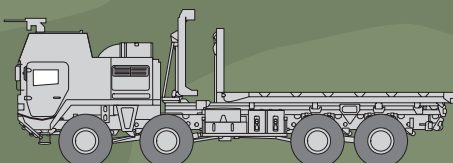

SX 45 MULTI 2 IAC (Integrated Armour Cabin)

### HX – suiting every task.

The HX is the all-rounder among all-wheel-drive trucks, developed for logistic requirements in tough military service. The perfect supply vehicle with superior off-road capabilities. Based on MAN's civilian TGA, it incorporates all of MAN's expertise in commercial vehicles and all-wheel-drive trucks. The HX combines the reliability of tested mass-produced components with state-of-the-art, innovative engineering. This makes it the most economical military vehicle in its class. And one of the most durable too, since it is designed for a service life of 20 years. With the variants 4x4, 6x6 and 8x8 the HX models cover a wide range of applications – from cargo/troop carrier through to heavy-duty tractor with gross train weights of up to 120 tonnes.

### SX – setting the benchmark.

With its unique off-road capabilities and torsional rigidity the SX sets the benchmark in mobility – high performance off-road. It can even get through where only tracked vehicles normally have the capability. The SX is the leader in its class and either the 3- or 4-axle vehicle is predestined for the transport of high-class, complex and sensitive bodies, ideal as a system and weapon carrier for tactical missions. Its solidity and reliability are unequalled. This is backed up by all of the experience which MAN has gathered with its high-mobility trucks deployed for decades by numerous armed forces around the world. The SX convinces with its outstanding service life of 30 years and more. All of its components are designed for top robustness and dependability. Its corrosion protection fulfils the requirement for optimum long-term protection. The SX – for top mobility.



## HX – High Mobility Truck System.

### **A strong basis – the ladder frame.**

The body-friendly, low torsion ladder frame of the HX is based on the tried and tested series frame of the civilian TGA range and is designed for service with a large off road proportion – reliability built-in. It is made of high-strength, fine grain steel and has riveted and bolted cross members and a steel bumper. Due to the low torsion frame, comfortable and gentle transport is guaranteed. The lateral acceleration acting on the platform or body is low.



### **Comfortable and robust – the leaf suspension.**

Like the frame the suspension has stood the test in many thousands of MAN vehicles. The leaf suspension further developed for the HX with long, wear-free, rubber mounted springs, large shock absorbers and stabilisers absorb most ground irregularities.

This gives the HX its comfortable running performance and roll-resistant handling – which is good for the body.

### **Well situated: Engine and cooling system.**

In the HX the diesel engine is situated under the cab. The thermostat-controlled cooling system and air intake can be found on top of the frame behind the cab which protects them from dirt and dust and allows for prolonged fording.

## SX – Extreme Mobility Truck System.

### 100 % torsional stiffness – the box-type frame.

The extremely torsion resistant box frame with hollow longitudinal members and welded tubular cross members put the SX in a class of its own. With this design the suspension absorbs even extreme terrain irregularities. The desired consequence: the body remains unaffected even during fast off-road driving.

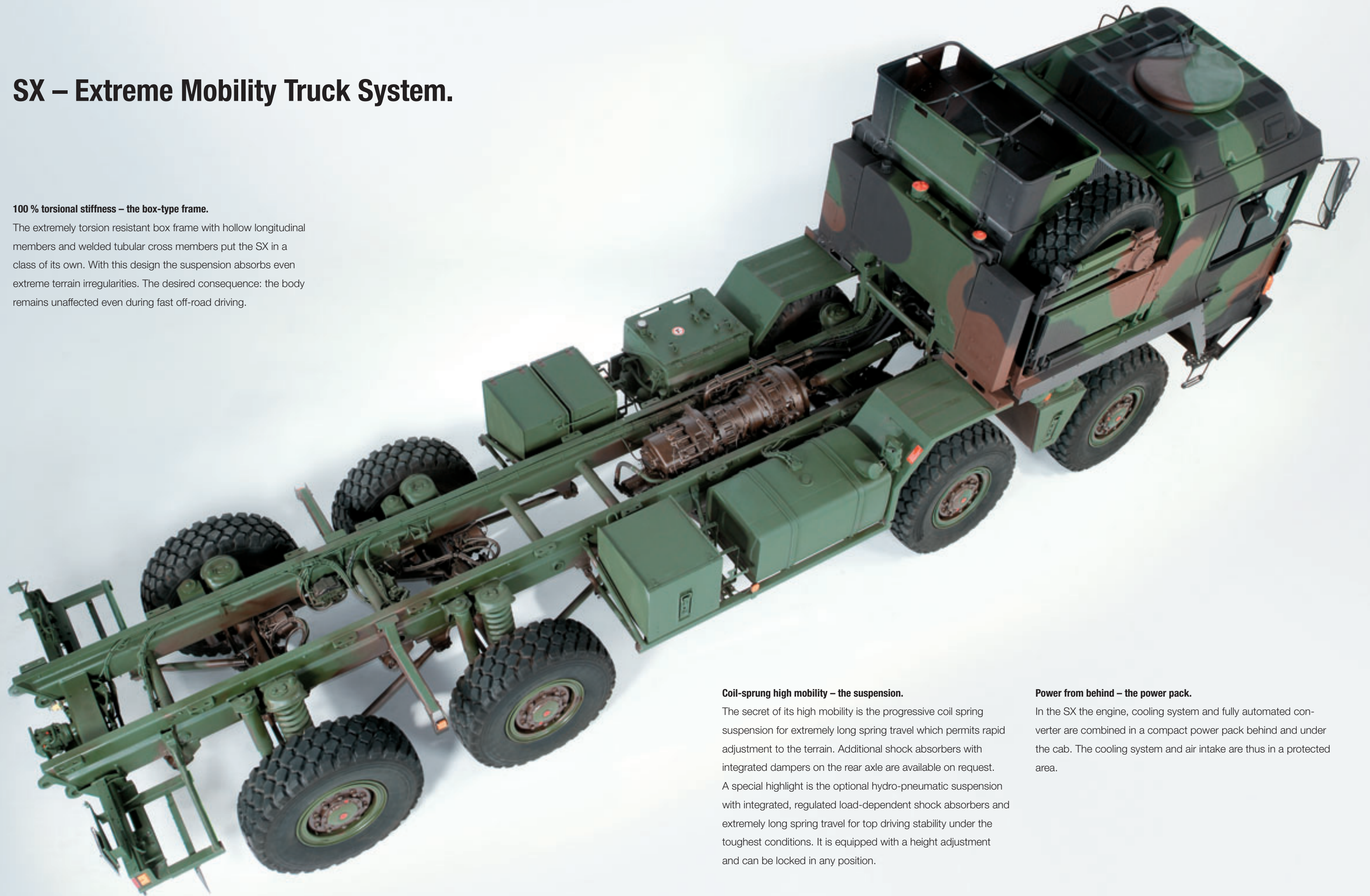

### Coil-sprung high mobility – the suspension.

The secret of its high mobility is the progressive coil spring suspension for extremely long spring travel which permits rapid adjustment to the terrain. Additional shock absorbers with integrated dampers on the rear axle are available on request. A special highlight is the optional hydro-pneumatic suspension with integrated, regulated load-dependent shock absorbers and extremely long spring travel for top driving stability under the toughest conditions. It is equipped with a height adjustment and can be locked in any position.

### Power from behind – the power pack.

In the SX the engine, cooling system and fully automated converter are combined in a compact power pack behind and under the cab. The cooling system and air intake are thus in a protected area.

## Special forces.



### Power politics – the common rail engines.

Enormous engine power, low fuel consumption and smooth running – these are the characteristic advantages of the MAN common rail diesel engine. Equipped with the maintenance- and clog-free particulate filter MAN PM-KAT® the six-cylinder and V8 engines fall within the pollutant limits in accordance with Euro 4. The SX and HX vehicles are fitted with the powerful engines from the D20 range. The D08 common rail engine is available for the HX 60 and HX 61. In the HX heavy-duty vehicles V8 engines supply unleashed power. The large, thermostat-controlled cooling system is designed for operation in the hottest climatic zone C1 (up to 49 Grad Celsius). Operation down to -32° Celsius is standard – with the optional arctic kit even down to -46° Celsius.

### All geared up – gearbox and transfer case.

In the HX power is converted to dynamics by the automated 12-speed MAN TipMatic gearbox – providing shifting comfort second to none. The MAN TipMatic can be activated both fully automatically and manually by a touch lever. The 3- and 4-axle semitrailer tractors in the HX range are fitted with the TC tronic, a combination of the MAN TipMatic with WSK 440 converter clutch unit – ideal for comfortable and wear-free maneuvering of heavy loads and for operation off paved roads. The classic fully automatic transmission is used throughout the SX range. It shifts smoothly and without interruption of the tractive force.

The MAN transfer cases used with electro-pneumatic differential locks are adapted to the engine power and offer maximum traction in all driving conditions.

### Getting through is everything – the planetary axles.

The planetary axles designed for the single tyres score points with their high ground clearance and great reliability. They are fitted with a differential lock.

### Air for more – tyre inflating and pressure control systems.

A tyre inflating system can be supplied to adjust the air pressure in stationary vehicles, as can a pressure control system which permits controlled deflating and inflating of the tyres even during driving. The tyre pressure can thus be adjusted according to the surface conditions within no time at all.

### Halt on command – the EBS brake system.

On command the dual-circuit air brake system with the electronic brake system EBS responds effectively. It also has ABS, with a special off-road logic for reliable use on loose ground. The brake pedal actuated EVB engine brake, relieves the wheel brake and provides additional safety.

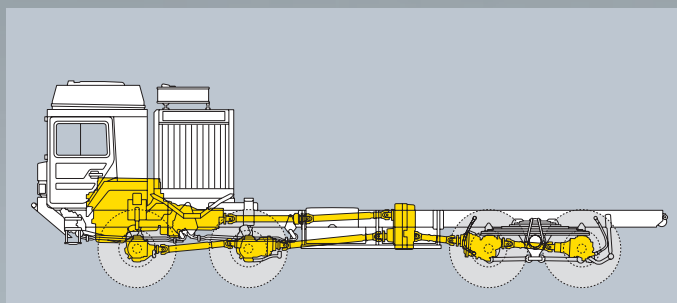

MAN HX: High Mobility Truck System with a low-torsion ladder frame, leaf suspension, single tyres and permanent all-wheel drive. Engine situated under the cab, cooling system behind the cab.

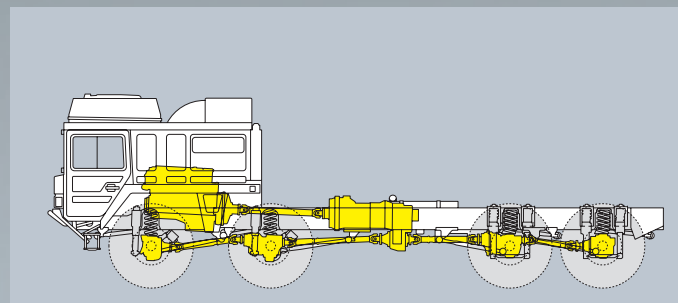

MAN SX: Extreme Mobility Truck System with a torsion-stiff box frame, progressive coil suspension, single tyres and permanent all-wheel drive. Engine and cooling system behind the cab.





## Room on the top.

### The modular cabs.

With their striking and individual appearance, functional design and equipment, and dependable service characteristics the modular cabs in the HX and SX range not only look impressive and solid: they are. Over the years they have been consistently developed to optimally meet the requirements of the armed forces and procurement authorities. The result are cabins which set the standard: from the comfortable entry and crossover through to their hardtop everything satisfies the demand for functionality. The modular cab designed in steel is also available for the HX in a version extended by 310 mm.

### Windows/mirrors

- Detonation-proof windscreen in two sections for reasonably-priced replacement
- Windscreens installed vertically to minimise light reflection
- Sun blinds standard
- Electrically adjustable and heatable rear-view mirrors

### Air conditioning

- Powerful heater/ventilator with raised air inlet
- Rapid de-icing of windscreen and side windows
- Air conditioner integrated in the aluminium hardtop roof, auxiliary heater available as optional equipment

### Cockpit

- Steering wheel adjustable in height and inclination
- Instrument panel with clear displays corresponding to the TGA civilian range
- Large central LC display
- Instrument lighting can be dimmed and is off when camouflage lighting is in operation
- Interior lighting and reading lamp provide optimal illumination

### Seats

- 2 seats with integrated headrests and 3-point automatic belts, the central seat with a 2-point lap belt
- Air-sprung comfort seats for the driver and co-driver
- Folding central seat back serves as a platform to climb up to the roof or as an observation/machine gun banquette
- Additional 4-seat bench in the extended HX cab

### Stowage space/bunks

- Spacious shelves/stowage compartments for personal equipment and military accessories
- Practical rifle holders in the doors
- Machine gun holder and holder for light anti tank weapon within easy reach
- Preparations for radio and intercom systems and GPS
- Two-bunk system optional

### Hardtop

- Walkable and removable hardtop roof
- Flat hardtop roof made of synthetic, optionally with pivoting roof hatch and machine gun ring mount
- High hardtop roof made of aluminium, optionally with a pivoting roof hatch and machine ring gun mount, with an integrated air conditioner
- Opening diameter of the roof hatch 800 mm
- Ring mount attachments for different weapons
- Stowage box for camouflage nets behind the hardtop roof



## A shield of armour.



### Safety first.

Such expressions as asymmetric warfare, the fight against terrorism, improvised explosive devices and suicide bombings reflect a threatening scenario in which the protection of the crew is a great challenge. In light of this MAN has developed effective cab protection which meets every conceivable requirement. The options range from modular protection through to integrated protection against assault rifle fire, shrapnel and mines.

### Modular Armoured Cabin (MAC).

The protective equipment consists of armoured modules which are attached to the outside of the cab. Owing to the cubic shape and the flat outside surfaces of the cab the protection against assault rifle fire (Level 2) and mines (Level 1) can be easily and quickly mounted and removed by just two men. The space and ergonomics inside the cab remain unaffected by the attachment of the armour.

### Integrated Armour Cabin (IAC).

The all-steel design of the cab is a convincing response to today's threatening conflict scenarios. In accordance with STANAG 4569 it offers reliable protection against assault rifle fire and shrapnel (level 3) and against AT blast mines (level 3b). To permit the crew to react appropriately to attacks the armoured cab can optionally be equipped with a weapons station for a heavy machine gun or automatic grenade launcher. The weapons station can be operated from inside the cab, keeping the crew out of harms way. This option is offered by MAN in cooperation with leading manufacturers.



## Ready made.



### First class order: Maintenance and care.

The cab can be hydraulically tilted to a position ideal for work on the engine and gearbox, air drier, solenoid and ventilation valves. For day-to-day checks the front panel gives access to the engine oil filler neck, containers for the washer fluid, brake and other electric connections. The oil

reservoir for the supply of the steering and auxiliary hydraulics is situated behind the cab. Thanks to the sight glasses the fluid level can be checked at a glance. The cab floor can easily be sprayed out with a water hose for cleaning.

### Reporting for a wheel change: The spare wheel.

The spare wheel is intelligently stowed behind the cab and can be easily handled with a hoist. The wheel can be changed without difficulty by 2 men in no time at all.

### Without interference: The electronics.

The entire electronics system is adapted to the tough service conditions. It is shielded and electromagnetically compatible in accordance with EMC and NEMP. The central electrics are mounted in a protected position on the co-driver's side in the cab. The headlights and lighting correspond with civilian standards, the masked lights with military standards.

### Space for more: Stowage boxes.

The system carriers attached to the frame make it possible to fit modular stowage boxes as required by the customer. The easily accessible stowage boxes are water-tight and connected to the central ventilation system. Within these system carriers, fuel canisters, tow bars and entrenching tools can be mounted as required. The system carriers also accommodate the batteries, compressed-air tanks and the fuel tank.

### Mission possible: Recovery and self-recovery equipment.

The HX and SX ranges are fitted with recovery eyes in accordance with valid military standards. Trailer couplings are available in accordance with civilian and military standards. A cable or gypsy winch can also be supplied as an option for recovery or self-recovery.



### Constant reporting: Telematics.

The internet based telematics system opens new ways of fleet guidance, fleet management and logistics. Keywords such as tracking & tracing, assignment notification and destination guidance, route planning, help calls and technical vehicle deployment analysis illustrate the wide range of functions available. The HX and SX vehicles are prepared for the use of MAN Service telematics.

### Always on duty: Integrated Logistics Support (ILS).

Among other services ILS offers user training in the MAN training centre or at the location of the vehicles, preparation of technical handbooks in any language desired and the delivery of spare parts and special tool packages.

HX: Recovery equipment front



SX: Recovery equipment front



Centrally vented stowage box, fording tight



HX: Recovery equipment rear



SX: Recovery equipment rear

# The line-up.

Selection of service applications

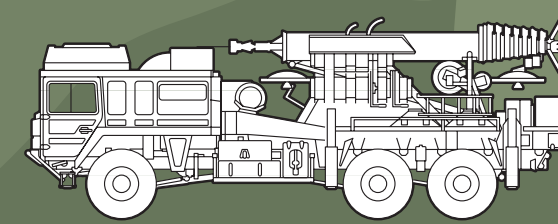

SX 44 Antenna Mast Carrier

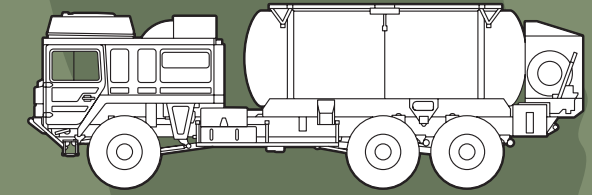

SX 44 Tanker

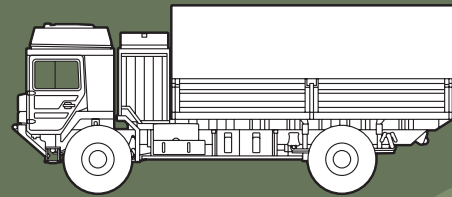

HX 60 Cargo/Troop Body

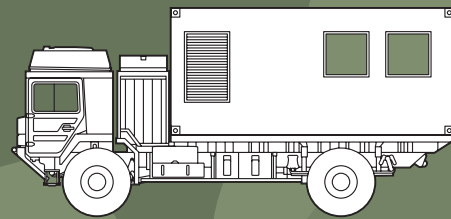

HX 60 Cabin

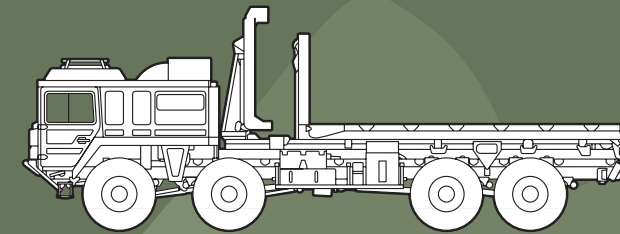

SX 45 Load Handling System

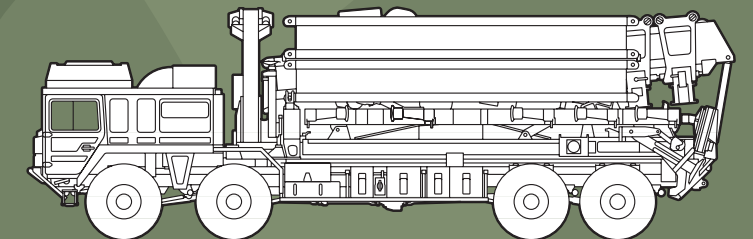

SX 45 Bridgelayer

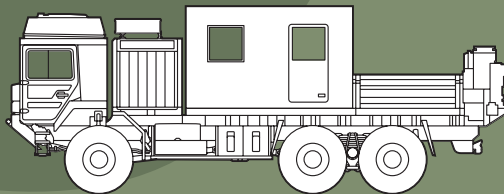

HX 58 Cabin

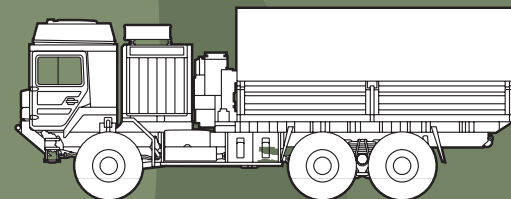

HX 58 Cargo/Troop Body

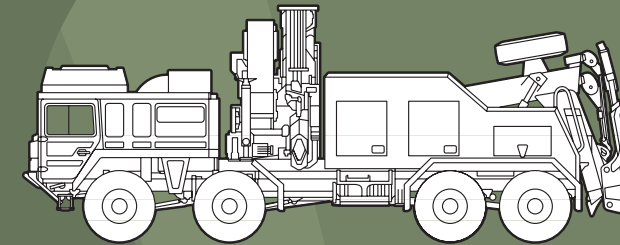

SX 45 Recovery vehicle

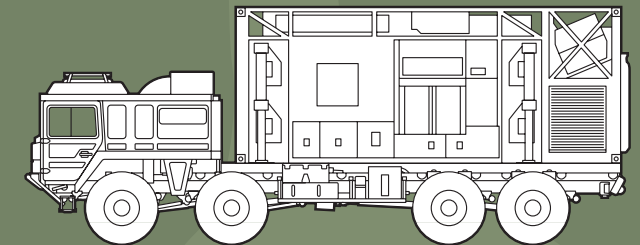

SX 45 System Cabin

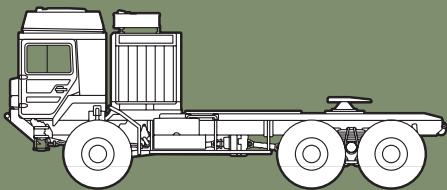

HX 80 Tractor

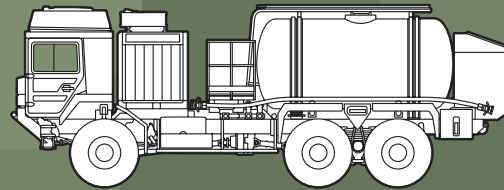

HX 58 Tanker

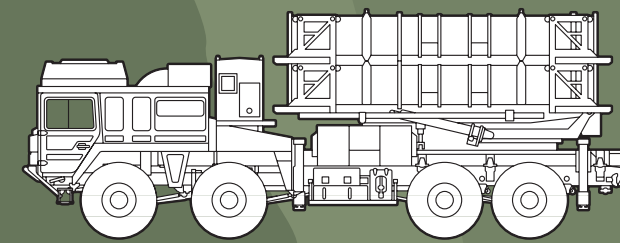

SX 45 System Carrier

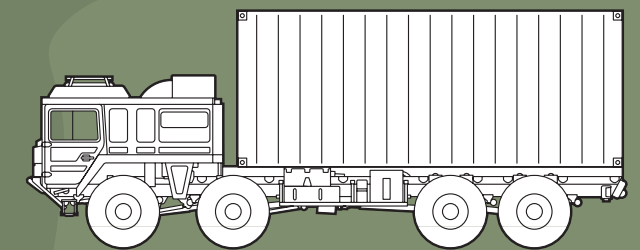

SX 45 Container

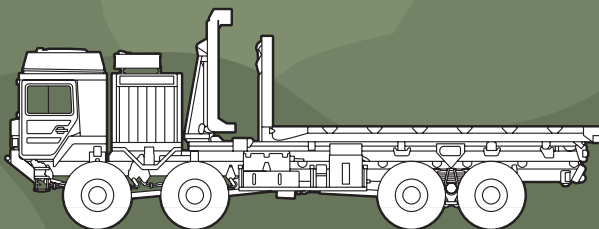

HX 77 Load Handling System

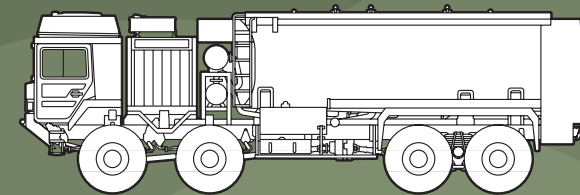

HX 77 Tanker

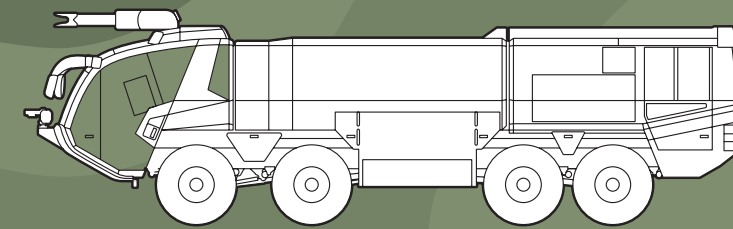

SX 40.1000 Fire Fighting Vehicle

MAN Nutzfahrzeuge Group  
Business Center Military  
P.O. Box 50 06 20  
D-80976 Munich

E-Mail: [militarytrucks@man-mn.com](mailto:militarytrucks@man-mn.com)  
[www.man-mn.com/militarytrucks](http://www.man-mn.com/militarytrucks)

A member of the MAN Group



D111.3350/E – mu 05065 – Printed in Germany  
Text and illustrations not binding.  
We reserve the right to make changes in the course of technical progress.