

T908



AUSTRALIAN MADE. WORLD'S BEST.

TRADITIONALLY TOUGH

A TRUCKING ICON

The Kenworth T908 has become part of Australia's landscape, renowned for its long-bonneted, traditional, tough good looks and its even tougher performance.

The T908 excels in many applications ranging from general freight right through to logging, livestock and mining.

Whether in single trailer or multi-trailer road train configuration, on highway or the roughest outback track, the T908 has been designed and built in Australia to deliver unmatched performance in the harshest possible conditions.



AUSTRALIAN MADE. WORLD'S BEST.

UP CLOSE & TECHNICAL

T908'S ARE TAILOR MADE TO YOUR APPLICATION

We look carefully at your specific application and performance requirements and engineer our best possible combination of chassis, engine, transmission and driveline.

Through application engineering at the design/specification phase, the features and benefits that best meet your needs can be built in at the factory level as an integrated solution, delivering life-long performance and reliability.

For example, for dangerous goods and flammable liquids haulage we build Fuel Haul Kits to the most exacting standards, using only the finest quality materials. Features include stainless steel exhaust shielding, manual reset circuit breakers, hazard plate holders, PVC shielded wiring, premium isolation switching to isolate the electrical system, and an insulated battery box.

CHASSIS FRAME LAYOUT

Kenworth trucks can be built to virtually any wheelbase with components mounted onto the frame to suit your individual needs.

Kenworth's are custom-made trucks with a wide range of options. The Kenworth hauling a roadtrain across the deserts of Australia is as 'application-specific' as the one dragging its load of ore through the mud track in Papua New Guinea.

We maximise the strength of each frame by locating the various parts so that loads are evenly spread and fuel tank capacity can be maximised. Battery boxes are positioned to minimise the length of battery cables for ease of starting and to ensure the batteries are subjected to the lowest possible shock loads.

FUEL TANKS

At Kenworth trucks we design our own fuel and oil tanks. Engineering fuel tanks specifically for an application can deliver cost savings by setting up a truck so it can refuel where you want it to. Aluminium tanks are standard for weight saving, or you can select steel tanks for severe applications.

All these features are examples of Kenworth's unmatched attention to design, function and quality.

T908 Aero 50" Integrated Sleeper

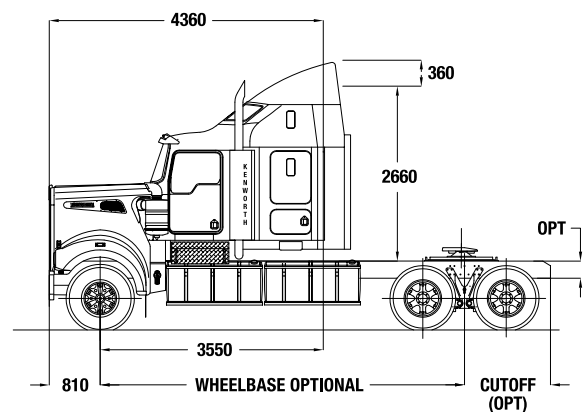

T908 36" Recessed Back Sleeper

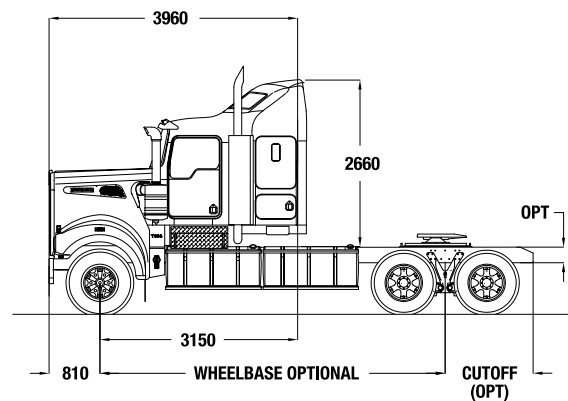

T908 Day Cab

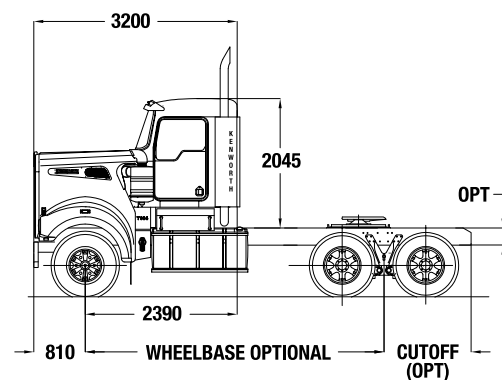

- Large storage compartments each side under the sleeper bunk and in the centre, with optional rear access.
- Optional Day Cab, 28", 36" or 50" integrated sleeper boxes.
- Optional 36" or 50" modular sleeper boxes.

- Legendary Kenworth cab appointments featuring luxurious colour co-ordinated trim and aircraft style instrumentation.
- Large external air cleaners, with twin stage cyclonic action for maximum cleaning of intake air in outback conditions.
- Remote keyless entry.

- Choice of Cummins engines to meet requirements up to 615 hp and 2050 lbf.
- Choice of either single or two piece windscreen.
- Stainless steel sunvisor.

- Stainless clad aluminium bumper or optional bullbar are factory fitted so that towing points are integrated into the chassis structure. FUPS 'Texas' style bumper available.
- Durable grille and exterior fittings.



- The widest range of specialist heavy duty rear axles to suit your application.

- Custom engineered fuel/oil tanks available in round or rectangular configuration to maximise fuel capacity.

- Long perforated steps allow plenty of choice on where to put your feet. Perforations allow mud to be scraped off and drop through.

- Cooling packages specifically designed to meet Australia's toughest conditions for greater durability and reliability.

AUSTRALIAN MADE. WORLD'S BEST.

THE COMMAND CENTRE

DRIVER COMFORT AND SAFETY

Classic styling has been teamed with the highest standards of driver comfort and safety in the T908 cab design.

The large one-piece curved windscreen offers a commanding view of the road ahead with excellent all round visibility. Daylite doors with drop-down glass sections deliver added sideways vision and safety. Two-piece windscreens are available as an option for those that prefer the traditional look.

An unobstructed view of gauges and easy access to vital switches and controls are provided by the cleverly designed wraparound dash, enhancing driver comfort and minimising fatigue.

Apart from the comprehensive standard gauge layout, you can choose from a wide range of optional gauges and instruments to meet your individual needs.

The overhead console features separate dimming and gives good access to the electrical switches, the CD AM/FM radio and storage compartment.

Headlights are safely actuated by a separate toggle switch, and engine brake and cruise control are conveniently mounted on the steering column. A gentle red light under the dash illuminates the floor and reduces driver tunnel vision and fatigue.



AUSTRALIAN MADE. WORLD'S BEST.

THE WORLD'S BEST REST STOP



The best looking truck in Australia is also possibly the most comfortable.

Enjoy home away from home comfort with “walk through” sleepers that offer unsurpassed levels of accommodation comfort.

The T908 can be optioned with any of Kenworth's range of traditional sleeper boxes. Configurations range from the IT flat roof 28 inch sleeper, an aerodyne 36 inch to the luxurious 50 inch Aero design, offering cupboards with hanging space, full head room, ample storage and optional second bunk. Each integrated cab-sleeper has diamond pleated and studded soft trim in a range of colours and Kenworth's unsurpassed appointments.



AUSTRALIAN MADE. WORLD'S BEST.

PURPOSE BUILT FOR YOUR NEEDS

ENGINES TO HELP KEEP YOUR COOL

The latest engine technology is available for the T908 from Cummins in a range of horsepower and torque ratings that allow you to specify and fine tune your truck specifically for its application. Electronic engine management allows us to tailor an engine to your exact needs, for longer, trouble-free and more cost effective operation, improving durability and assisting in reduced fuel consumption.

With extremes of temperatures and humidity, Australia has some of the toughest operating conditions in the world, so we have been careful to design and test all our cooling packages in Australia. That's why the class leading cooling package leads to reduced excess fan cycle on time, in even the harshest Australian conditions.

REAR AXLE SUSPENSIONS

All Kenworth suspensions are of the highest quality with proven performance and reliability.

A suspension unique to Kenworth is the eight air bag AIRGLIDE. This suspension is excellent for ride and handling across many applications ranging from white goods and produce to fuel haul.

For mining, roadtrain and some off highway applications Kenworth offer the tough durable and low maintenance six-rod Kenworth KW6-60A suspension, renowned for its legendary longevity in the toughest conditions.



DRIVETRAIN

To get power to the ground, we offer a selection of proven drivetrain components for the T908 from the best suppliers available including transmissions from Eaton and Allison, coupled with drive axles from Meritor and Dana.

ATTENTION TO DETAIL

At Kenworth even the smallest component of the T908 has to be the best or it is not fitted.

Many of our trucks operate in extreme levels of dust and dirt. Where possible we double clamp all piping on the clean air side of the intake system to double the 'clean air' protection.

The electrical system is one of the most important part of any truck which is why we have independent circuits to each high beam headlight and there are screw on terminals on all circuit breakers and gauge senders.

Collectively these sorts of details deliver big improvements in quality and reliability, longer life and higher standards of safety.



Piping bundle tied every 150mm.



Double clamping provides extra engine protection.



Screw on terminals don't shake loose.



Spring loaded constant torque clamps stay tight.

AUSTRALIAN MADE. WORLD'S BEST.



THE MOST PROFESSIONAL DEALER NETWORK

Every Kenworth truck is supported in the field by an extensive network of highly qualified dealers throughout Australia, New Zealand and Papua New Guinea. Each dealer has a history of excellence in the heavy duty truck industry.

Kenworth's on-line parts system provides owners with unmatched service. And each dealership has a complete Bill of Material for every Kenworth truck built, so when you want a part for your truck, there's no guesswork.



MADE IN AUSTRALIA

Kenworth trucks are designed and manufactured in Australia to perform in some of the toughest and most demanding applications found anywhere in the world. They are application engineered to exacting standards, using the best technology and componentry.

On a whole-of-life cost basis, there are few trucks that can approach Kenworth in helping to produce a better bottom line for your business.



AN ENVIABLE RECORD

From its beginning in Bayswater, Victoria in 1971, Kenworth's Australian operations have developed into a world class design, development, manufacturing and testing facility incorporating advanced training services and its sophisticated PACCAR Parts warehouse and distribution centre.

With around 40,000 Australian made trucks delivered, Kenworth Australia provides products and services to the transport sector that are the envy of the industry worldwide.

AUSTRALIAN MADE. WORLD'S BEST.

THE BEST DEALER NETWORK

Kenworth has built an extensive truck dealer network across Australia that is renowned for its professionalism and excellence in the heavy duty truck industry. The Kenworth dealer network also includes highly qualified dealers in New Zealand and Papua New Guinea.



PACCAR

For more information contact your local Kenworth Dealer
or go to www.kenworth.com.au

IMPORTANT: The vehicles shown in this brochure are for illustrative purposes only and may include some non-standard optioned equipment. All weights and measurements should be regarded as approximate only. For full details contact your Kenworth Dealer. In the interests of product improvement, Kenworth reserves the right to change these specifications without prior notice.

PACCAR Australia Pty Ltd, 64 Canterbury Road, Bayswater, Victoria 3153
Telephone (03) 9721 1500 Facsimile: (03) 9720 4144

www.kenworth.com.au



PACCAR
FINANCIAL

AUSTRALIAN MADE. WORLD'S BEST.