

# T650

*“Rugged, reliable and tough. The Kenworth T650 is designed and built in Australia to handle the most brutal jobs this country has to offer, both on and off the highway. Whether you need to haul a triple road train on a back road, or a load of logs out of a forest, you’ll do it more easily and in more comfort and safety when you’re behind the wheel of a T650.”*



## Heavyweight performance

The T650 can be fitted with high horsepower CAT, Cummins and Detroit engines which offer you the power you need for the toughest on and off-road applications.

The high mounted cabin also allows for increased air flow to cool high horsepower engines operating in demanding, high ambient temperature conditions.

## Heavy duty strength and durability

If you need a truck that offers the strength and durability to handle the most rugged applications in Australasia's tough conditions then you should consider the Kenworth T650.

Designed with the versatility to operate in almost any application from logging to livestock, whether pulling a single trailer or a triple road train, the T650 will give you the performance and reliability that only a Kenworth delivers. Designed, proven and manufactured in Australia, the T650 is built to handle the most demanding operating conditions both on and off the highway, while keeping the driver comfortable and safe.



## Designed for rugged operation

Two distinctive design features of the T650 which make this truck unique are the set back front axle and high mounted cab. The set back front axle offers excellent steering characteristics, such as improved manoeuvrability and reduced turning circles. These are of particular importance in difficult conditions like off-road logging sites.

The high mounted cab set back from the engine means that there is no engine intrusion into the cabin. This allows for easy all round access to the engine, making servicing and maintenance fast and efficient.

The high mounted cab also allows flexibility in the frame layout. Batteries can be located under the cab, leaving more room on the frame for fuel tanks or shortening the wheelbase.

If you prefer to have tool boxes under the cab, the batteries can also be frame mounted.



*Set back front axle.*



*Under-cab tool box.*



***“Built to handle anything –  
on or off the road.”***



## Driver Comfort and Safety

The cab has been ergonomically designed for the professional driver. The sloping hood offers excellent forward vision and the DAYLITE doors, with drop down glass section, improve sideways vision and increase safety.

The raised cab allows for greater air flow, reducing engine heat transfer into the cabin and improving driver comfort. Long front springs ensure that the driver experiences the smoothest possible ride in all conditions thereby contributing to increased overall comfort and safety.

## Design Flexibility

The latest options and horsepower ratings from North American engine manufacturers can be specified on the T650 giving you the power you need to get the job done.

Matched with the latest in transmissions and rear axles, the T650 can be ordered to exactly meet your operating needs.

The T650 can also be fitted with the full range of Kenworth manufactured sleeper boxes, available in 36 inch and 50 inch sizes with the standard flat roof or a range of aerodynamic roofs and/or fairings.

A range of suspension packages is available, including the road friendly Kenworth Airglide 200.



*Excellent visibility.*



*Comfortable sleeper.*

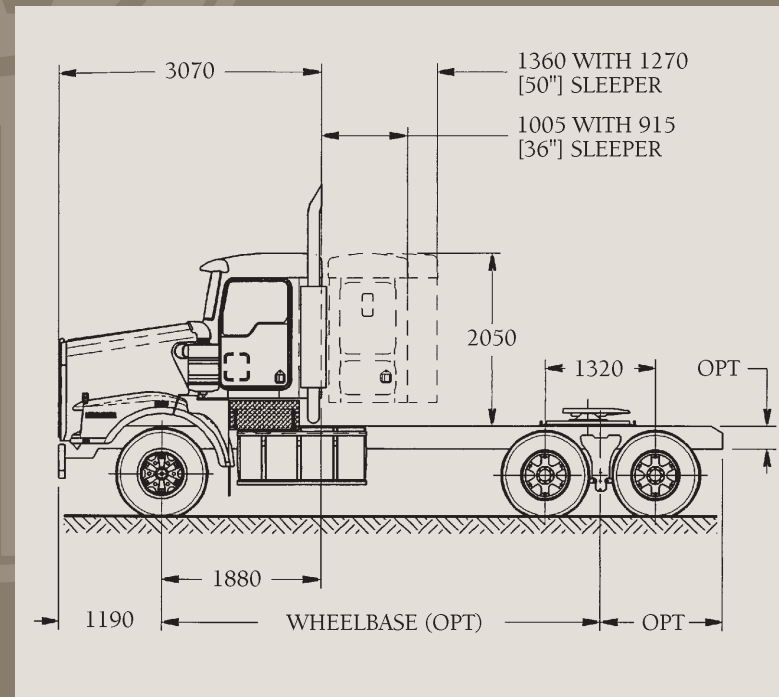

*T650 with or without base sleepers.*



*Stylish dash layout.*

