

K104

“If you require a cab-over truck that can be tailored to suit a variety of applications, then the Kenworth K104 is your best choice.

Available in both flat roof and Aerodyne variants, the K104 has been designed with the versatility to operate in single trailer, B-Double and B-Triple applications, as well as twin steer operations for mining sites, heavy logging and other specialist applications.”



Design Flexibility

The K104 can be ordered in a number of different specifications to ideally suit a range of applications.

For exceptionally demanding work where maximum load carrying capacity is imperative, the K104 can be ordered with twin steer axles allowing more weight to be distributed over the front axles. This makes the truck ideal for heavy duty haulage, logging or mining applications.

For applications where a sleeper is preferred, the K104 can be ordered with a 2.3 metre cab which is perfectly suited to B-Double operation, or the 2.9 metre cab for ultimate space and comfort.

The Power to Move

The K104 allows you to choose from the latest technology in engine design. Select from the Caterpillar C12 at 410hp, all the way up to the C16 at 600hp. Alternatively, Cummins provide a range from the ISM at 350hp, up to the Signature 620 at 631hp. Detroit Diesel has the Series 60, with the choice from 452hp up to 550hp. What other COE can offer you such power, but the K104?



Driver Comfort and Safety

The K104 has been designed with the professional driver in mind. Entry grab handles make access into and out of the cab easy. Four way mirrors assist the driver to see what is happening behind the truck. The large, deep windscreen, coupled with daylite doors and optional peeper window, maximise visibility for added safety.

The wrap-around dash provides excellent vision and allows easy access to all controls, reducing the need for unnecessary movement during driving. Rocker style switches ensure positive operation and an optional adjustable steering column makes it easy for the driver to achieve their optimum driving position.

The double skin engine tunnel, with ducts constantly cooling the air between driver and engine, effectively reduces heat and noise transfer from the engine, adding to driver comfort.

The cab roof design accommodates the deep windscreen. The overhead console allows for maximum utilisation of space, without compromising visibility, headroom or serviceability.

Great Visibility

The K104 is fitted with a two-piece curved windscreen as standard, offering excellent visibility. An optional one-piece windscreen is available for even better visibility. The one-piece windscreen has a three-blade wiper and high capacity motor.



Optional fold down second bunk bed increases space and accommodation when you need it.



Deep windscreen, daylite doors and four-way mirrors ensure maximum visibility.



Aerodynamic Performance

The K104 2.3 metre Aerodyne has been designed to maximise both cab size and trailer hauling capacity. The ideal truck for operation in B-Double applications, the K104 2.3 metre Aerodyne is also perfectly suited for operation in B-Triple applications. Advanced fibreglass and aluminium construction result in low tare weight and maximum strength. Add to this the aerodynamic performance and you have the perfect truck for maximising your payload and productivity. To further reduce air drag and improve efficiency, a roof-mounted deflector can be fitted to the aerodynamic model.

The K104 has an external sunvisor bolted directly to the roof, which has been developed to suit the cab roof profile and to improve aerodynamics.

For the ultimate in cabin size, comfort and luxury the K104 Aerodyne 2.9 metre length model is available, which maximises space for the driver in the cab.

The K104 offers the reliability, durability and performance that only a Kenworth can deliver.”



Spacious Working Environment

Kenworth have incorporated a range of innovative features in the cab to create a large and comfortable working environment for the professional driver.

In addition to the interior features offered with the K104 flat roof, the Aerodyne provides maximum space, luxury and the latest in technology. It can be ordered with a single bunk or twin bunks for two-up driving.

The high aerodynamic roof with dual vista windows provides exceptional headroom in the cab. Natural daylight also filters through the vista windows.

The cab can be fitted with a range of overhead lockers and storage shelves. There is also the option of fitting a TV and VCR for relaxation during rest periods, while a fridge can be mounted on the engine tunnel to keep refreshments cool. Driving performance and sleeping comfort are unsurpassed in the K104 Aerodyne.



Optional fridge mounting on engine tunnel.



Wrap-around dash layout.

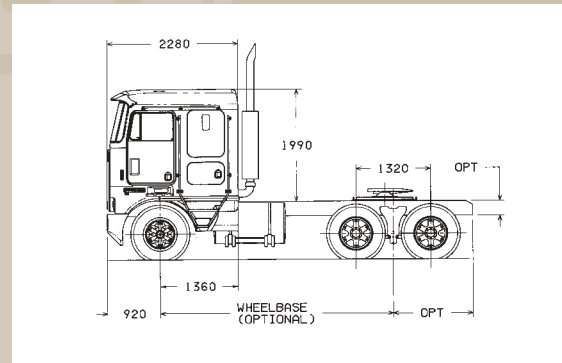

K104 (2.3m)

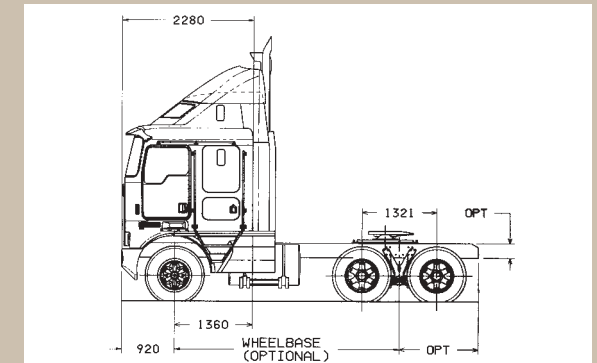

K104 (2.3 Aerodyne)

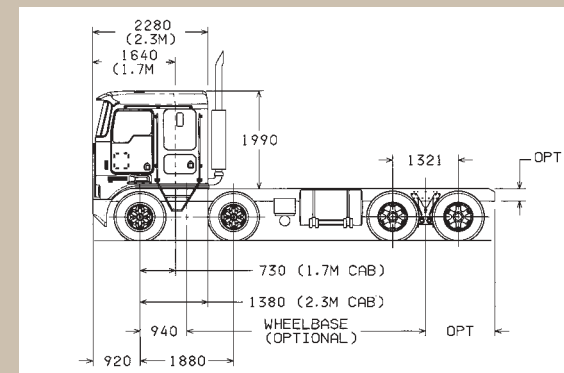

**K104 (8x4)
1.7m and 2.3m cab**

