



# *The DAF LF Series*



*Dedicated to distribution*





# ***Designed to deliver***

*The DAF LF Series has been a winner right from the start. With its modern and spacious cab design, low chassis weight for the highest payloads in its class, tight turning circle for maximum manoeuvrability, easy cab access and car-like driving characteristics, the DAF LF Series is the ideal partner for city and regional distribution. More powerful engines with low emissions at Euro 5 levels, optional AS-Tronic automated gearbox, a stylish exterior and upgraded interior design, make the LF Series even more attractive than its award-winning predecessor.*

*EEV models\* with even lower emission are available to suit use in cities with environmental zones. The LF Series, designed to deliver.*



\* Enhanced Environmentally-friendly Vehicles.





*At home in town and country*

# ***The perfect partner for distribution***

***DAF's LF Series offers superb manoeuvrability, easy cab access, low kerb weights for class-leading payloads, comfort, performance and fuel efficiency. The ideal distribution truck, with GVWs from 7.5 to 21 tonnes. Smooth and comfortable for the driver. Reliable, flexible and economical for the operator. Furthermore, the modern design of the LF reflects your company's image. The DAF LF Series is not only ideally suited to town and country, it will also meet the needs of longer trips.***

The exterior design gives the LF a sturdy appearance. The pronounced upper and lower grille with aluminium strip to signify compliance with the Euro 5 and EEV emission standard, the larger mirrors for a large field of vision, and the cat's-eye combi-lights, all give the LF a modern look.

### ***Inviting interior***

Open the door and you immediately experience the quality of the LF interior. Indeed, the styling and standard of finish more resemble that of a luxury passenger car. The colour schemes and materials used mean that the LF cab offers a pleasant, comfortable working environment. The dashboard and modern instrument panel, the adjustable steering wheel with integrated controls and optional airbag, and the well positioned handles and switches, all demonstrate how the creation of an ergonomic working environment was a key target in the design process of the LF Series.

### ***Powerful engines***

Maximum torque is available over a wide rev range for all four- and six cylinder PACCAR engine ratings, resulting in better performance, greater

flexibility and less gear-shifting. The LF Series offers power ratings from 140 to 300 hp and all engines comply with Euro 5 and EEV emission standards, thanks to the high pressure common rail injection system and SCR after-treatment technology.

### ***AS-Tronic automated gearbox***

For the LF Series the AS-Tronic gearbox is an option on all vehicle types. This automated six-speed gearbox employs an electronic system to select the right gear for every situation, resulting in better fuel efficiency and enhanced driver comfort. And as the driver can fully concentrate on traffic conditions, the AS-Tronic gearbox improves safety too. 'Two pedal' driving makes the ideal distribution truck even easier to operate.

***Superb manoeuvrability, easy cab access, low kerb weights for class-leading payloads, comfort, performance and great fuel efficiency.***







*Modern, distinctive and fit for purpose*

# ***Dedicated to productivity***

***Trucks like the DAF LF Series are used in many different applications, from urban and regional distribution to long distance lightweight transport and special applications such as roadsweepers, refuse collectors or fire engines. This versatility requires an extensive vehicle range to achieve greater productivity in every transport application.***

Productivity starts with the right choice of specifications. The DAF LF series therefore includes many different gross vehicle mass, wheelbase and engine power options, as well as the choice of Day Cab or Sleeper Cab. The LF45 is available in GVMs of between 7.5 and 12 tonnes, whereas the LF55 covers GVMs from 14 up to 21 tonnes, while offering a maximum train weight of up to 32 tonnes. In all versions, the low kerb weight ensures best-in-class payload for the highest productivity.

## ***Compact yet spacious***

Both the Day Cab and the Sleeper Cab combine compact external dimensions for maximum manoeuvrability and loadspace with a surprisingly spacious interior. The easy access, excellent visibility and ergonomic controls are evidence that the driver has been the focus of attention in the development of the LF. The wide, deep windscreen and narrow pillars provide excellent visibility, while green-tinted glass helps keep the cab cool. The six mirror layout provides a larger field of vision for greater safety. The LF has four-point cab mountings to maximize comfort.

Noise and vibration levels are even lower due to new engine and cab mounts, resulting in more driving comfort, less driver fatigue and more safety.

## ***Stylish and functional***

The modern exterior design of the LF is certainly important; the truck is the operator's business card on the road. But for every DAF truck functionality has been an even more important development driver. The durable steel bumper – a trusted DAF feature – is only one example of this design philosophy, as are the virtually unbreakable Lexan covers on the high-intensity headlamps, all help to minimize minor accident damage. Optional cat's-eye combi-lights further enhance safety. The corner spoilers, integrated in the design, help minimize road spray fouling the door handles, electrically adjustable side mirrors and windscreen. Aerodynamic options such as the roof spoilers and top/side collars improve fuel economy. For additional comfort an integral designed external sun visor is also available.



***Modern design and functionality go hand in hand in the DAF LF Series.***









*The tachograph is practically positioned in the header shelf.*



*An invitingly spacious interior. The bunk in the Sleeper Cab features a full-size mattress of 2 m long, 70 cm wide and 12 cm thick.*



*The AS-Tronic control panel is located on the console next to the driver's seat.*

*An interior that suits every driver*

# *A great place to work*

*The LF's interior is designed around the driver's needs. With fully adjustable seats, controls logically grouped around the driving position, and a dashboard that would look at home in a luxury passenger vehicle, it is an ergonomic place to work.*

Trucks designed for local and regional distribution and urban deliveries frequently stop and start for loading and unloading. Such operation demands easy entry and exit, so the LF has a large illuminated entry step and a door that opens to a full 90°. Good cross-cab access allows the driver to easily get out on the co-driver's side, an important feature in inner-city distribution.

### ***Extra driver comfort***

The LF cab interior has a sense of space and light. The high-backed driver's seat is fully adjustable and available with air suspension for optimum comfort. A co-driver seat is standard, but a dual passenger seat is available too, for three man seating.

Special attention has been given to the new interior colours and trim, with less frequently used areas in light, warm shades, and intensively used areas in darker, easier to clean colours. As a result, the LF cab will still look good after many years of intensive use, good for resale values. What else do drivers value? The many storage areas for delivery notes, writing materials, road maps etc.

### ***A place for everything***

Storage facilities are class leading, with compartments that provide ample room to carry items. There is space for maps and papers in the door panels, central cup holders, flat over-dashboard storage and two compartments in the header shelf complete with nets. A cargo net is also located on the back wall. The Sleeper Cab has three additional storage units beneath the bed. The header shelf also accommodates the tachograph, easily within reach.

### ***Comfort at night***

At night, the interior lighting provides even distribution throughout the cab. There are two surface-mounted lights in the Day Cab roof, and four in the Sleeper Cab. The bunk in the Sleeper Cab features a full-size mattress of 2 m long, 70 cm wide (60 cm behind the seats) and 12 cm thick, as well as blackout curtains.

*A comfortable, inviting and functional interior that uses available space to the maximum.*





*Comfort and convenience in a safer environment*

# ***Uncompromised ergonomic design***

***From the logical grouping of switches on the dashboard to the backlit controls on the steering wheel and driver's door console, it is clear that safety and ease of operation were given the highest priority in the design of the LF Series.***



*Cruise control, standard on every LF.*



*Modern and ergonomic dashboard design.*



*Optional dash-mounted position for mobile phone, pre-wired for 'hands free' connection with most GSM phones and steering wheel controls.*

The thick-rimmed, four-spoke steering wheel is comfortable and gives unhindered view of the instruments. The steering wheel is generously adjustable in rake and angle and incorporates an optional airbag and illuminated switches for cruise control, exhaust brake and adjustable speed limiter. Additional switches for a hands-free telephone can also be specified. The steering wheel, however, is only the first touch of quality when driving the LF.

### ***Well-thought-out***

The cockpit-shaped dashboard is well-thought-out and has all controls easily within reach in logical positions. When fitted, the AS-Tronic control panel is conveniently located on a console next to the driver's seat. All handles and controls are there where you expect them. One of DAF's main objectives in the design of the LF was that its controls should be intuitive. Just get in and drive!

### ***Information on request***

The modern instrument panel with purpose-designed layout has stylish aluminium highlights. Offering excellent clarity with minimal reflection, the main gauges provide information on primary functions. The central information display presents only essential vehicle information when

needed or at the drivers request. This ensures that the driver is not unnecessarily distracted but still receives any relevant information. The LCD information display offers a choice of 32 different languages, and also provides information on trip duration, fuel consumption, average speed and PTO hours.

### ***Heating and ventilation***

The LF Series is equipped with a generously dimensioned heating and ventilation system. On distribution trucks this is an important feature as the doors are continually being opened and closed. In winter, a lot of the heat escapes and the interior needs to be restored to a comfortable temperature as quickly as possible. A lot of attention has of course been devoted to the demisting of the front windscreen and side windows to guarantee unrestricted visibility at all times. Air conditioning is available on all models, as is a night heater for the Sleeper Cab.

***One of DAF's main objectives in the design of the LF was that its controls should be intuitive. Just get in and drive!***



*The 4.5 litre four cylinder PACCAR FR engine is available with outputs from 140 hp to 207 hp with standard EEV.*



*The 6.7 litre six cylinder PACCAR GR engine offers maximum outputs from 220 hp to 300 hp.*



*High-pressure commonrail injection, for powerful and economical engines.*

## *Four- and six-cylinder engines*

# *The comfort of power*

*The LF Series is equipped with four- and six-cylinder PACCAR engines, developed to meet the latest Euro 5 and EEV emission standards. Furthermore, the four-cylinder PACCAR FR engines are all standard available in versions that meet the stringent EEV emission standards. The 4.5 and 6.7 litre engines are designed to offer high levels of efficiency, reliability and durability to the operator and smooth, comfortable power to the driver.*

Building on the reputation for reliability, performance and fuel economy of the PACCAR Euro 4 engines, the Euro 5 and EEV engines have higher performance rates. Both the modern four- and six-cylinder engines in the DAF LF are characterized by electronically controlled high pressure common rail diesel injection in combination with SCR technology. The four-cylinder PACCAR FR engines are all standard available in versions complying with EEV emission requirements. EEV specifications are optionally on the six-cylinder PACCAR GR engines.

### ***140 to 300 efficient horses***

The LF Series offers a wide choice of power ratings to suit every application in the most efficient way. The 4.5 litre four cylinder PACCAR FR engine is available with outputs of 140 hp, 160 hp, 185 hp or 207 hp and torque levels of 550 Nm, 600 Nm, 700 Nm and 760 Nm respectively. The 6.7 litre

six cylinder PACCAR GR engine offers maximum outputs of 224 hp, 250 hp, 286 hp or 300 hp with corresponding torque figures of 850 Nm, 950 Nm, 1,020 Nm or 1,100 Nm. Importantly, the maximum torque is available from as low as 1,200 rpm, resulting in greater flexibility and less gear shifting.

### ***Powerful benefits for operators***

Lower operational costs, and enhanced vehicle availability and durability were important development drivers for the LF Series. The PACCAR engines in the LF Series not only offer better performance, they also offer larger service intervals of up to 55,000 km depending on vehicle type and type of operation.

The standard exhaust brake and cruise control, are actuated by the steering wheel switches, offering increased braking performance and relaxed driving, contributing to driver comfort and lowering operating cost.

*The PACCAR Euro 5 and EEV engines for the LF45 and LF55 provide a higher output combined with a high torque.*



## Unbeatable driving characteristics

# A joy to drive

**Like every DAF, the LF Series too is characterized by superb driving properties and excellent manoeuvrability. A great deal of attention has been devoted to ideally match chassis design, steering, brakes and suspension. This, together with the high torque characteristics of the engines and comfortable cab design, makes the LF Series a joy to drive under all circumstances.**

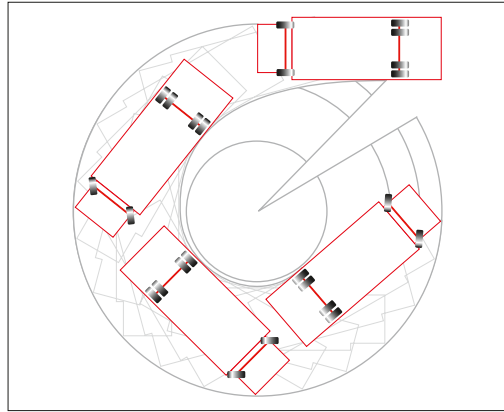

Compact dimensions and a large wheel turn angle result in the smallest possible turning circle for optimum manoeuvrability.



**Tyre Pressure Indication**



**Actual and targeted fuel consumption is given on the display in the instrument panel.**

The spacious cab with comfortable seating position, excellent visibility, ease of operation, comfortable suspension and tight turning circle for great manoeuvrability all form the basis for enjoying every mile in an LF. As do the PACCAR engines for great performance, the smooth ride and accurate steering behaviour for excellent road holding and power steering for minimum effort even at low manoeuvring speeds. Add to this a whole range of safety enhancing features, including the optional steering wheel airbag, and the ideal distribution truck is born: the DAF LF Series, offering maximum driving pleasure for the driver.

A correct tyre pressure saves fuel, increases tyre life and reduces the risk of a sudden tyre damage.

All LF vehicles have Tyre Pressure Indication that generates tyre pressure warnings on the instrument panel.

For the operator, the LF Euro 5 and EEV vehicles offer a solid foundation for low cost of operation and high transport efficiency, combined with the highest standards of quality and reliability for optimum availability. And finally, the LF is designed for durability, resulting in higher resale values.

To challenge the driver to the most fuel efficient driving style, information on the actual and realized fuel consumption is given on the display integrated in the instrument panel. Comprehensive trip fuel information is available after engine shutdown for further evaluation.

Engine idle shutdown to prevent unnecessary running of the engine with stationary vehicle and thus waste of fuel, is available as an option.

### **Comfort and safety systems to rely on**

DAF Trucks offers a wide range of comfort and safety options for the LF Series. In addition, all DAF trucks are designed to offer industry-leading comfort and a best in class human-machine-interface, to keep the driver safely in control in the most comfortable way.

### **Braking Systems**

- Anti-lock Braking System (ABS)
- Anti-Slip Control (ASR)

### **Vision**

- Front and electrically adjustable side view mirrors

### **Drivers support, passive safety systems**

- Tyre Pressure Indication
- Seat belt reminder
- Airbag and seat belt pre-tensioners
- Front and rear under-run protection

*DAF SCR Technology for a bright future*

# *The clean route*



*The compact lay out of the DAF SCR installation leaves enough free space on the chassis for large fuel tanks and other equipment.*

*Depending on the vehicle type, AdBlue tanks are available with a capacity of between 26 to 70 litres: a capacity that corresponds to the diesel fuel tank capacity. This means that the AdBlue tank does not have to be filled more often than the diesel tank. And for optimum ease of use for the driver, an AdBlue level gauge is fitted to the dashboard.*

DAF uses SCR technology – Selective Catalytic Reduction. This SCR technology offers the best solution to comply with the strict European Euro 5 and EEV emission requirements. SCR technology is simple, reliable and efficient. As SCR is an after-treatment system, the most efficient combustion techniques can be used in the engine itself. And DAF goes even further. DAF SCR Technology is applied in an entirely new series of PACCAR engines with an advanced high-pressure fuel injection system.

### **How does it work?**

It's simple and effective. Basically the exhaust gas after-treatment system consists of a catalytic converter, a dosing unit and an AdBlue tank with at least enough capacity to match the range offered

by the fuel tank. The exhaust gases are led through the Selective Catalytic Converter, where AdBlue is injected. A chemical process takes place, resulting in NOx emissions being broken down into harmless water vapour and nitrogen. AdBlue consumption is only 1 litre per 100 kilometres. The AdBlue tank on the LF has a capacity of 26 or 70 litres. For the LF Series, this is sufficient for a range of 2600 to 7000 kilometres, so that drivers will not have to fill the AdBlue tank too often.

### **EEV (Enhanced Environmentally-friendly Vehicle) engine**

All four-cylinder PACCAR FR engines meet the stringent EEV emission levels as standard. The six-cylinder PACCAR GR engines are available in EEV version optionally.







## *Integrated drive line technology*

# ***Manual or automatic***

***An economical engine is only the starting point for an efficient drive line. Gearbox and rear axle are equally important when it comes to efficiency and keeping cost per kilometre as low as possible. That is why DAF has been focussing for many years on integrated and optimal drive line technology. The improved drivelines in the LF Series are further proof of this philosophy.***

The LF Series offers an extensive selection of gearboxes and rear axle ratios. There is a choice of refined, smooth shifting 'H' pattern five-, six- or nine-speed manual transmissions. Shifting through the gears with the short and direct gear lever is a joy, making the driver's life easier, even in heavy traffic.

### ***Automated gear shifting***

To further optimize comfort and efficiency, AS-Tronic six-speed gearboxes are available as an option on all LF types. This automated gearbox employs an electronic system to select the right gear for every situation, resulting in lower fuel consumption and enhanced driver comfort. Because the driver can fully concentrate on the traffic, an AS-Tronic gearbox can improve safety too. For special applications, such as fire

engines or refuse collection vehicles, a fully automatic five-speed Allison transmission is available.

### ***Reliable, economic rear axles***

To cater for many applications, the LF Series has a range of DAF single reduction rear axles. These axles have earned an excellent reputation for long service life, excellent reliability, and above all, low internal resistance. This means less energy losses in the drive line resulting in better fuel consumption. The wide selection of rear axle ratios available, allows the selection of exactly the right driveline for each individual application. ASR anti-slip control that prevents spinning of the drive wheels, is available as an optional extra.

***AS-Tronic automated gearboxes are available as an option for the LF.***



*Console type body mounting brackets are used to enable easy installation of the body.*

*A totally flat chassis with pre-drilled holes makes body builders' life a lot easier.*



*Totally flat chassis for easy body mounting*

# ***Designed for high payloads***

***To satisfy as many distribution needs as possible, the LF is available in various wheelbases and axle configurations, including tractors and a three-axle rigid with steered trailing axle. The chassis layout and positioning of components has been optimized, to minimize vehicle weight and optimize the available space for auxiliary equipment. More payload and lower costs per kilometre were the design criteria for the chassis too.***

The LF-chassis is made of high quality steel, resulting in an exceptionally strong but lightweight chassis for high payloads. It is completely flat, making it the ideal base for any superstructure. To make the bodybuilder's job as easy as possible, the main frame members are pre-drilled to ensure easy mounting of the body. Body mounting brackets are available as an option.

### ***Best-in-class payload***

Strong, but as light as possible for best-in-class payloads, a totally flat chassis to make the body builder's life easier, and great durability and reliability. These were the main design principles behind the development of the chassis of the DAF LF Series. The result: exceptionally high payloads, varying from 4.0 tonnes with a GVM of 7.5 tonnes on the lightest LF45, to 13 tonnes on the 18 tonnes version of the LF55. The LF55 with steered trailing axle even combines a payload of around 15.5 tonnes with maximum manoeuvrability. All LF's feature a considerable front axle load tolerance to prevent overloading in case of partial loads.

### ***Brakes and suspension***

Depending on the configuration, the LF is available with parabolic springs or electronically controlled air suspension. For applications requiring a short rear overhang, such as refuse collectors, asymmetric leaf springs are available. Ventilated disc brakes all round provide positive but progressive braking bringing safety and controllability to the LF, in combination with the exhaust brake which helps to reduce brake pad wear.

### ***PTO programme***

In view of the wide range of applications of vehicles in the DAF LF45 and LF55 class, there is also a demand for a PTO in this segment. For example for a fridge unit, tipper or crane drive unit. Again the LF provides tailor-made solutions with a wide range of PTO options. As a new option FA LF55 vehicles with 6-cylinder engines can now be supplied with an indirect front-end PTO preparation for refrigerated transport.





LF HYBRID

HYBRID

DAF

LF

DAF  
48 180T



*State-of-the-art hybrid technology*

# ***Green distribution***

The new standard in environmental friendly distribution: DAF LF Hybrid. By using both diesel and electric power, fuel consumption and therefore CO<sub>2</sub> emission reductions of up to 20% can be achieved, depending on the application.

The 12 tonnes DAF LF Hybrid uses a so called parallel diesel/electric hybrid system. It is driven by the diesel engine, the electric engine or a combination of both.

## ***Diesel and/or electric drive***

Its 4.5-litre PACCAR FR diesel engine complies with the ultra-low EEV emission requirements. It offers a maximum power of 118 kW/160 hp and is linked to an automatic Eaton six-speed gearbox. Between clutch and gearbox an electric motor is installed. It can provide drive as well as function as a generator. Energy released during braking is stored in special lithium-ion batteries for re-use during acceleration. A central computer determines when the diesel engine provides the drive and when and to what extent the electric engine is used.

*PACCAR – DAF's parent company – is leading the way in the field of hybrid technology. In the United States, the Kenworth and Peterbilt brands offer a range of models where using diesel/electric hybrid technology significantly reduces fuel consumption and emissions. As part of PACCAR's international hybrid programme, the DAF LF Hybrid truck was developed in close collaboration with Eaton, Eindhoven University of Technology and Leyland Trucks Ltd, also a PACCAR subsidiary.*

## ***Start/stop system***

When the hybrid battery pack is fully charged, the LF Hybrid truck can travel a distance up to 2 kilometres on battery power without needing the diesel engine to drive it. In practice, this is enough to drive in and out of the “green zones” in city centres. The LF Hybrid is also equipped with a start/stop system for zero fuel consumption and zero emissions when standing idle.

Another advantage of hybrid technology is that components susceptible to wear, such as brake linings and clutch plate, will have a longer service life because braking occurs on the electric motor.

## ***Operational lease***

Hybrid technology will be developed further in the next few years, particularly with regard to batteries. That's why the DAF LF Hybrid is offered as standard via PACCAR Financial with a full operational lease contract. The DAF dealer can implement any potential updates during the contract term. This ensures that you always have the most environmentally friendly vehicles for a fixed price per month.









*Committed to world-class*

# ***Right first time***

DAF Trucks - A PACCAR Company - applies state-of-the-art technology to maintain the highest standards in development and manufacturing. Over the last few years, major investments have been made in all production facilities. DAF trucks are built in world-class facilities in Eindhoven (NL), Westerlo (B) and Leyland (UK), by dedicated people, using high-quality materials and efficient processes.

For the production of PACCAR engines, the engine factory has been totally renewed, making it one of the most modern of its kind in the world. In other factories too, major innovation programmes have been undertaken to achieve the highest efficiency and quality levels.

DAF Trucks introduced the PACCAR Production System to achieve world-class manufacturing standards: everything right first time, with no unnecessary loss of energy or materials and with the highest conceivable quality. As a result, world-class products are produced in world-class factories.

## ***Information Technology***

DAF Trucks and its dealers have information technology systems that track a truck and its components throughout its entire life cycle – from design and production to aftermarket customer support. Engineering applies powerful three-dimensional CAD/CAM techniques that seamlessly interface with the production systems; ensuring employees receive

detailed on-line work instructions. The vehicle data for each individual truck is centrally stored for guaranteed traceability, making it easy for dealers to check specifications and order parts – right down to the options fitted.

## ***Product Development***

The DAF Technical Centre offers comprehensive research development and testing facilities, including an anechoic chamber for noise measurements and a state-of-the-art engine laboratory. DAF also has an extensive proving ground for simulating road conditions so vehicle performance can be thoroughly tested. DAF Trucks delivers world-class vehicles designed in world-class development facilities by a world-class development team.

## ***EcoDesign and environmental policy***

DAF has had an environmental policy in place for over 10 years, covering all its activities, products, services and locations - including dealers. Its environmental care system is ISO 14001 approved. And DAF has achieved a 'Zero Waste to Landfill' status. Which means waste is either recycled, reprocessed, or used for generating energy. EcoDesign is the company's unique approach to environmentally responsible product design, and is concerned with ensuring that all DAF's products comply with the strictest environmental guidelines, from first concept to end-of-life recycling.



***DAF uses the PACCAR Production System: right first time;  
no waste of energy and materials; highest quality standards.***



Truck & Trailer  
Rental



PacLease

PacLease

PacLease

DAF

LF

DAF  
45.220





**A top-class support organization of more than 1,000 independent dealers.**



**DAF ITS: often copied but never equalled.**



*DAF's one stop shop offers a total transport solution*

# ***With you all the way***

Road transport is all about optimum efficiency, so DAF offers a total transport solution, designed to maximize earnings per kilometre. It is supported by a professional organisation and dealer network that helps customers choose the right vehicle, finance it, maintain it in perfect condition, and keep it running at all times.

DAF Trucks not only makes quality vehicles, but also has a first-class back-up organisation with more than 1,000 independent dealers in Europe. They provide support ranging from financial services to repair & maintenance contracts. Parts for truck and trailers are always available, supplied to workshops by PACCAR Parts Distribution Centres in the Netherlands, the United Kingdom, Spain and Hungary. Every week, over 3,000 shipments are made to dealers and customers across Europe and beyond – often within 24 hours.

### ***DAF MultiSupport Repair & Maintenance contracts***

Tailored to truck and customer needs DAF MultiSupport offers a fixed rate per kilometre for repair & maintenance, ensuring a perfectly maintained fleet without unexpected costs. DAF MultiSupport is more than just repair & maintenance; customers benefit from increased vehicle availability and reduced administration. Thereby, DAF MultiSupport provides peace of mind and enables fleet operators to focus on their core business.

### ***Tailor-made financial services***

PACCAR Financial has over 40 years of experience in the transport industry and we understand your business needs. Our services include financing the total truck combination, R&M contracts and insurance. PACCAR Financial is available at all DAF dealer locations, providing one-stop access for trucks and financial help – including solutions for national and pan-European operators.

### ***DAF International Truck Service (ITS)***

If something unexpected should ever happen, one telephone call to DAF's ITS gets the truck rolling again with minimum delay. Often copied but never equalled, ITS is on stand-by day and night, 365 days a year. Experienced employees mobilize the DAF service organisation, handling language and financial issues to ensure that a stranded truck is back on the road with minimum delay.

***At DAF, we understand better than anyone else that a truck has to keep moving.***

## The LF Series cab overview

### DAF LF45 Day Cab

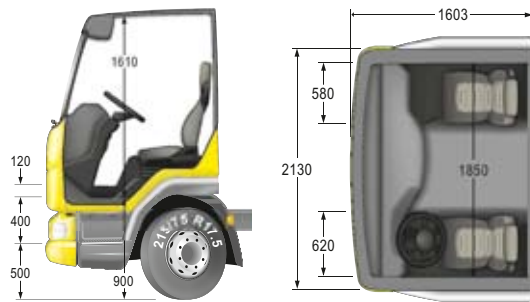

### DAF LF55 Day Cab

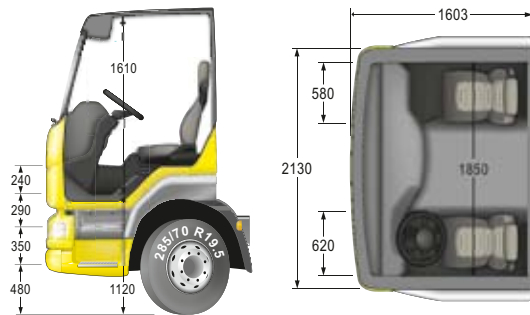



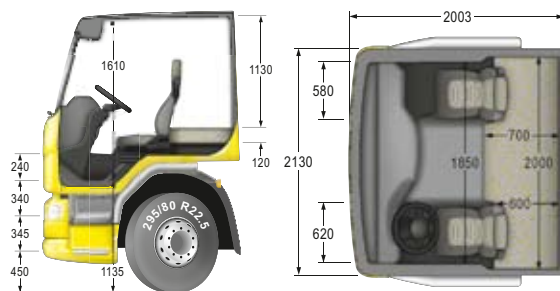

### DAF LF55 Sleeper Cab





## The LF Series axle configuration overview

LF45 — 17.5" wheels			
4x2	FA		GVM 7.5–12 tonnes GCM up to 22 tonnes
LF55 — 19.5" wheels			
4x2	FA		GVM 14-16 tonnes GCM up to 28 tonnes
6x2	FAN		GVM 21 tonnes GCM up to 24.5 tonnes
4x2	FT		GCM up to 28 tonnes
18-tonne LF55 — 22.5" wheels			
4x2	FA		GVM 18–19 tonnes GCM up to 32 tonnes

## The LF engine overview

Vehicle	Engine	Type	Performance	Torque	Emission level
LF45	PACCAR FR engine 4,5 litre, four-cylinder	FR103	103 kW / 140 hp at 1900-2500 rpm	550 Nm / 1200-1700 rpm	Euro 5 / EEV
		FR118	118 kW / 160 hp at 1900-2500 rpm	600 Nm / 1200-1800 rpm	Euro 5 / EEV
		FR136	136 kW / 185 hp at 2000-2500 rpm	700 Nm / 1200-1800 rpm	Euro 5 / EEV
		FR152	152 kW / 207 hp at 2100-2300 rpm	760 Nm / 1400-1800 rpm	Euro 5 / EEV
LF55	PACCAR GR engine 6,7 litre, six-cylinder	GR165	165 kW / 224 hp at 1900-2500 rpm	850 Nm / 1200-1700 rpm	Euro 5 / EEV
		GR184	184 kW / 250 hp at 1900-2500 rpm	950 Nm / 1200-1700 rpm	Euro 5 / EEV
		GR210	210 kW / 286 hp at 2100-2500 rpm	1020 Nm / 1200-1800 rpm	Euro 5 / EEV
		GR220	220 kW / 300 hp at 1900-2500 rpm	1100 Nm / 1200-1900 rpm	Euro 5 / EEV
LF55 18 tonnes	PACCAR GR engine 6,7 litre, six-cylinder	GR165	165 kW / 224 hp at 1900-2500 rpm	850 Nm / 1200-1700 rpm	Euro 5 / EEV
		GR184	184 kW / 250 hp at 1900-2500 rpm	950 Nm / 1200-1700 rpm	Euro 5 / EEV
		GR210	210 kW / 286 hp at 2100-2500 rpm	1020 Nm / 1200-1800 rpm	Euro 5 / EEV
		GR220	220 kW / 300 hp at 1900-2500 rpm	1100 Nm / 1200-1900 rpm	Euro 5 / EEV

LF45 engines

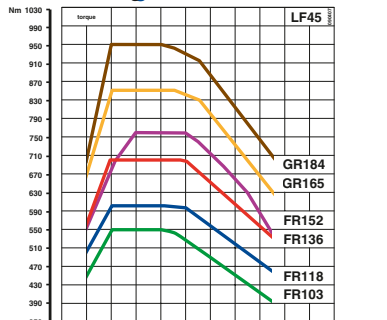

LF55 engines

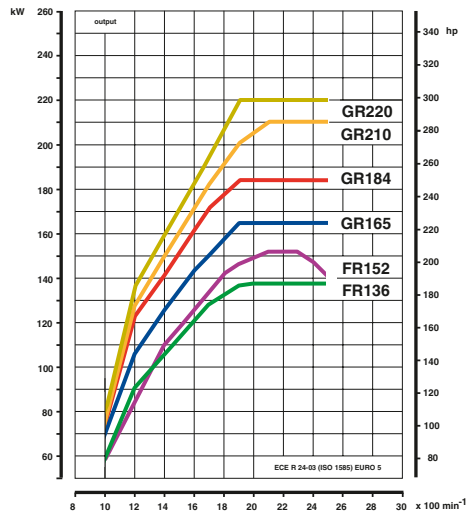
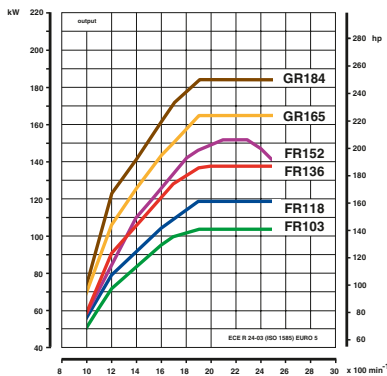
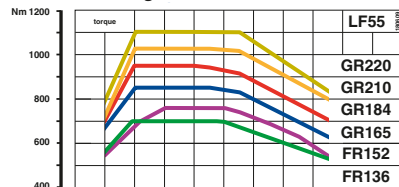

*More detailed product information on the different DAF vehicle series can be found in the specific DAF LF, CF and XF105 product brochures. For detailed product specifications, please refer to the technical specification sheets. For expert advice on the DAF solution for your particular haulage needs, please contact the sales advisors at one of our dealers.*





*The most modern product range on the market*

# ***A truck for every need***

*Every transport application has unique requirements, so every DAF vehicle is unique, built to order from a range of cabs, chassis, drive lines and axle configurations.*

*Three vehicle concepts – the XF105, CF and LF – one quality standard: the best. When ordering, the DAF sales consultant advises the customer using state-of-the-art software, ensuring the specifications exactly match the application.*

*Whatever the challenge, there's a DAF to meet it.*

*With a balanced selection of cabs, drive lines and axle configurations, there's a DAF truck that precisely matches your needs, whatever the application.*





No rights can be derived from this publication.  
DAF Trucks N.V. reserves the right to change  
product specifications without prior notice.  
Products and services comply with the European  
Directives effective at the time of sale but may  
vary depending on the country in which you are located.  
For the most recent information,  
contact your authorized DAF dealer.

Mirrors, bumpers and headlamp panel are not available ex-factory in body colour.

DAF Trucks N.V.  
Hugo van der Goeslaan 1  
P.O. Box 90065  
5600 PT Eindhoven  
The Netherlands  
Tel: +31 (0) 40 21 49 111  
Fax: +31 (0) 40 21 44 325  
[www.daf.com](http://www.daf.com)

DW14193505/HQ-GB:0411

*driven by quality*



ISO14001  
Environmental  
Management System



ISO/TS 16949  
Quality  
Management System



**DAF**  
A PACCAR COMPANY

